



6.1 - Introduction and methods

In the project design of a belt conveyor, after having defined the components of primary importance, it is important to consider other accessories such as covers for the conveyor.

The necessity to protect belt conveyors may arise from the weather, from the volatile characteristics of the conveyed material, or from the type of works plant, and also from European norms that require the covering of the total length of a belt conveyor in the open.

For example rain may create a problem of belt slip on the drums causing a tracking problem.

Extreme temperatures may cause the plant to mal-function or stop, whilst very strong wind may move the conveyor belt off its natural position causing serious problems to the business or loss of conveyed material.

6.2 - Styles and characteristics

Belt conveyors covers do not require maintenance and are very easy to install and move around.

The fixing system is designed in a way that allows quick and easy relocation of the covers to facilitate the inspection of the conveyor.

There are two styles of covers that are proposed: those in pre-formed PVC and those in corrugated galvanised sheet steel.



Covers series CPTA in steel

The covers proposed are made from galvanised sheet steel corrugated section. They are self supporting, safe, easy to install and adjustable to any structure. On request they can be supplied in other materials or finished with special paint.

They are available for all belt widths and supporting structure and can be supplied with opening windows for inspection and there are also removable covers and ventilated covers for hot environmental conditions.

They are maintenance free.

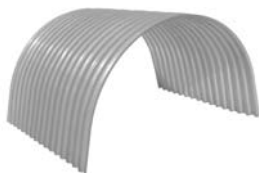

Covers series CPTin PVC

Plastic covers, made of preformed anti-shock, neutral colour, transparent PVC. Thanks to the characteristics of the material, they are light, transparent, anti-corrosive and with a smooth surface. Above all they are easy to adapt to any conveyor.

Apart from their resistance to corrosion they are classified "NON FLAMMABLE" DIN 4102.

Notwithstanding this property of self-extinguishing, the limit to the use of PVC covers in hot areas should not exceed 65°C.

6 Covers

6.3. Covers series CPTA in steel



6.3 - Covers series CPTA in steel

The covers shown in this catalogue are the result of many years' experience and cooperation with engineering companies and constructors specialising in belt conveyor design.

Why cover belt conveyors?

To protect the conveyed material.

To protect the environment:

- against dust
- against noise
- and for a better integration in the landscape.

For the operators' safety.

For the protection of the belt:

- against the sun and bad weather
- and for a longer life.

For the protection of the materials:

- with reduction of maintenance to the structures
- to avoid loss of materials and productivity due to wind
- to avoid deposits of rain water on the belt
- to assure the efficiency of the industrial constructions linked to the belt.

Material:

- galvanised steel for construction according to EURONORM EN 10 147 of 1996
- class S 220 GD + Z 1.0241

-Z35 Standard covering:

- Z 350 hot galvanisation on both sides
- 12.5 μ m each side.

Covering options according to the environmental conditions and the conveyed materials:

- Z45: Z=450 hot galvanisation, 16.0 μ m each side
- Z60: Z=600 hot galvanisation, 21.5 μ m each side

Other types of covering:

- PPE: Pre-Painting on galvanised steel
Z 225 polyester 25 μ m
- PVD: PVDF 35 μ m
polyvinyl thermoplastic resin
- SOL: Solifarm 25/35 μ m
soft polyester resin
- PVL: Plastisol 100 μ m
thermoplastic resin of polyvinyl chloride

Other materials on request:

- ALZ: aluzinc AZ 185
- AL: aluminium
- I04: stainless steel AISI 304
- I16: stainless steel AISI 316



Characteristics

Produced from galvanised sheet steel corrugated section 18/76 for all belt conveyors but normally used for belt widths of 400 mm upwards.

Length:

Standard module

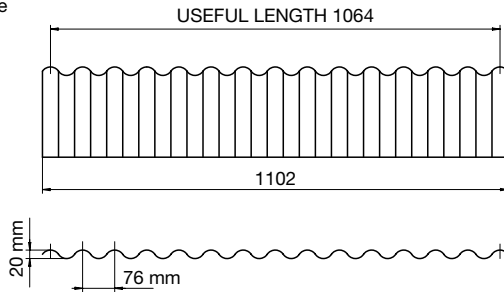

Intermediate module

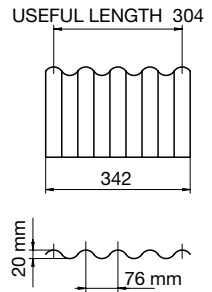

Standard lay-out

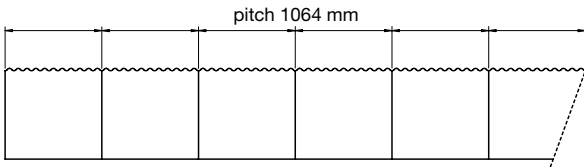

Standard lay-out (with alternate covers 180° - 135°)

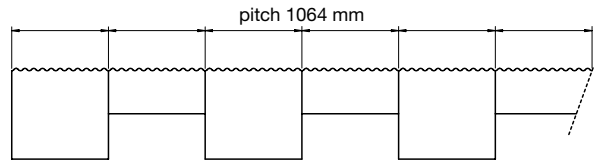

Lay-out with intermediate module at 180° and covers at 135°
(allowing a better view of the belt)

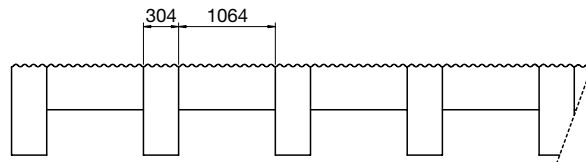

COVER AT 180°

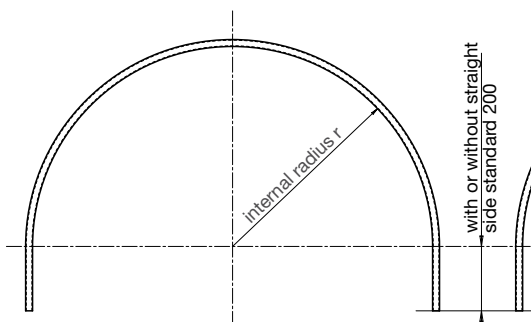

COVER AT 135°

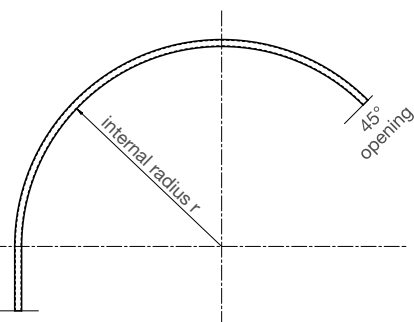

6 Covers

6.3.1 CPTA 1 Half circle with straight side

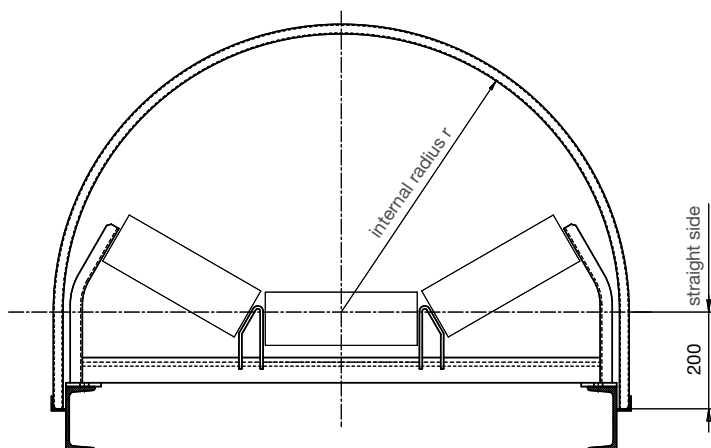

CPTA 1, 180° standard straight side 200 mm
(other lengths on request)

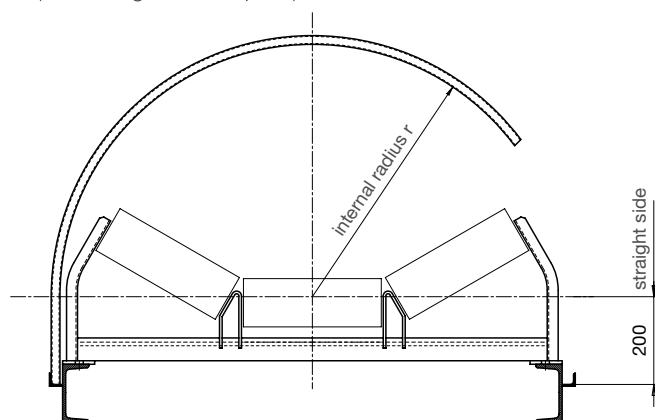

CPTA 1, 135°



Ordering code example:

CPTA 1 1600/1025 180/1064 P200 FG H30 Z35

type _____
 belt width/radius _____
 degrees/ length _____
 straight side
 (standard P200) _____
 with or without punching
 (F with punching, - without punching) _____
 fixing type
 (B, G, S) _____
 punching height _____
 material/covering
 (standard Z35 – see page 284) _____

Cover Type	Belt width mm	Radius r mm	Standard Length 1064 at 180° kg	Open Length 1064 at 135° kg	Cover at 180° length 304 kg	thick mm	Door 45° kg
CPTA 1	400	350	11.7	8.0	3.05	0.75	5.0
	500	400	12.9	8.7	3.37	0.75	5.4
	650	475	14.7	10.2	3.84	0.75	5.8
			16.5	11.6	4.32	0.75	6.3
	800	575	17.0	12.0	4.47	0.75	6.5
			18.8	13.4	6.59	1	6.9
	1000	675	19.5	13.8	6.80	1	7.1
			21.3	15.2	7.42	1	7.5
	1200	800	22.5	16.0	9.80	1.25	7.9
			24.3	17.4	10.59	1.25	8.3
	1400	900	24.9	17.9	10.85	1.25	8.5
	1600	1025	27.8	20.1	14.60	1.50	9.3
1800	1125	30.2	21.9	15.85	1.50	9.9	

Note:

For fixing accessories please refer to page 292-293. (*) radius on request

6 Covers

6.3.2 CPTA 2 Half circle without straight side

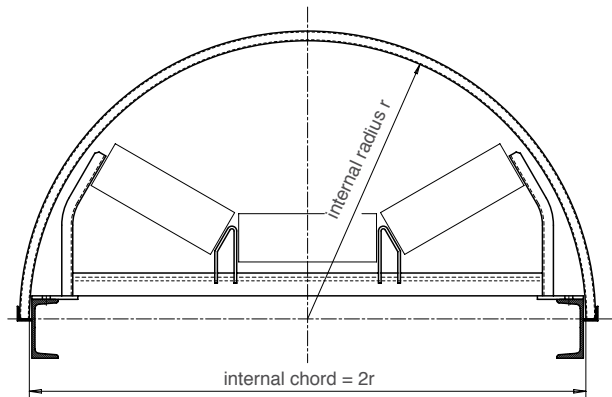

CPTA 2, 180°

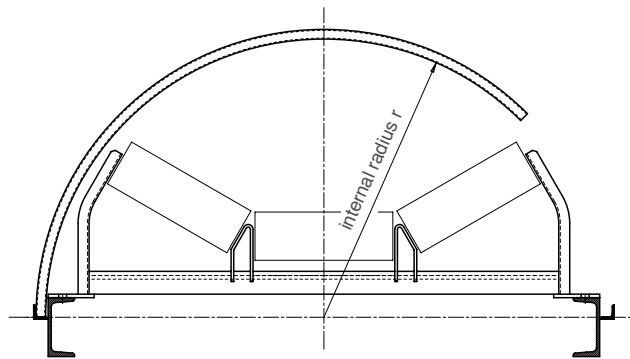

CPTA 2, 135°

Ordering code example:

CPTA 2 1600/1025 180/1064 FG H30 Z35

type _____
 belt width/radius _____
 degrees/ length _____
 with or without punching
 (F with punching, - without punching) _____
 fixing type
 (B, G, S) _____
 punching height _____
 material/covering
 (standard Z35 – see page 284) _____

Cover Type	Belt width mm	Radius r mm	Standard Length 1064 at 180° kg	Open Length 1064 at 135° kg	Cover at 180° length 304 kg	thick mm	Door 45° kg
CPTA 2	400	350	8.6	6.5	2.24	0.75	3.5
	500	400	9.8	7.4	2.56	0.75	3.7
	650	475	11.6	8.7	3.03	0.75	4.3
		550 *	13.4	10.0	3.51	0.75	4.8
	800	575	14.0	10.5	3.66	0.75	5.1
		650 *	15.8	11.8	5.51	1	5.4
	1000	675	16.4	12.3	5.72	1	5.7
		750 *	18.2	13.7	6.34	1	6.0
	1200	800	22.5	14.5	8.45	1.25	6.2
		875 *	19.4	15.9	9.24	1.25	6.8
	1400	900	21.2	16.3	9.5	1.25	7.0
	1600	1025	24.8	18.6	12.99	1.50	7.6
1800	1125	2.2	20.4	14.24	1.50	8.1	

Note:

For fixing accessories please refer to page 292-293. (*) radius on request

6 Covers

6.3.3 CPTA DOOR 45° inspection door for CPTA 1 and CPTA 2

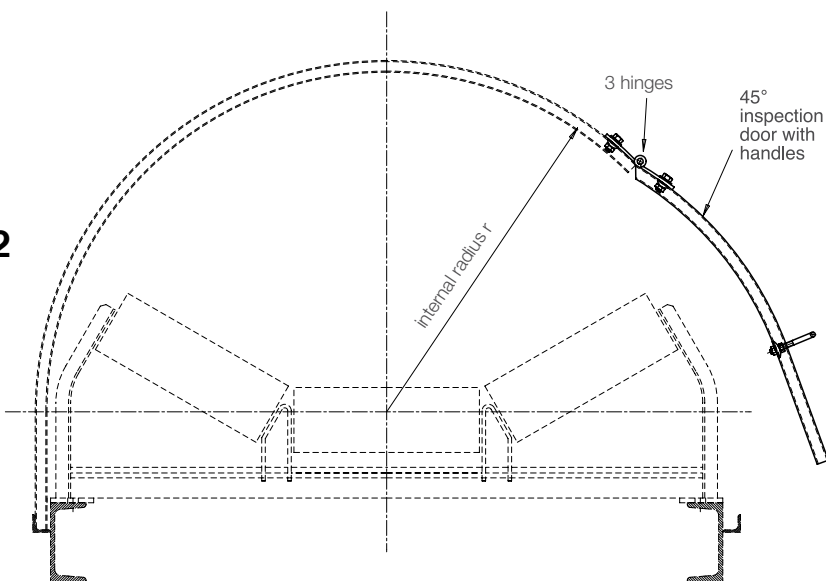

The standard supply includes:

- One 45° door with straight side (to be specified)
- 3 hinges
- 1 handle

- 2 fixing brackets
- zinc-plated bolts to fix the above mentioned parts

We supply loose components.

Ordering code example for the inspection door:

CPTA DOOR 1 1600/1025 P200 H30 Z35

type _____

belt width/radius _____

straight side (standard P200) _____

support profile height _____

material/covering (standard Z35 – see page 284) _____

CPTA DOOR 2 1600/1025 H30 Z35

type _____

belt width/radius _____

support profile height _____

material/covering (standard Z35 – see page 284) _____

Assembling example:

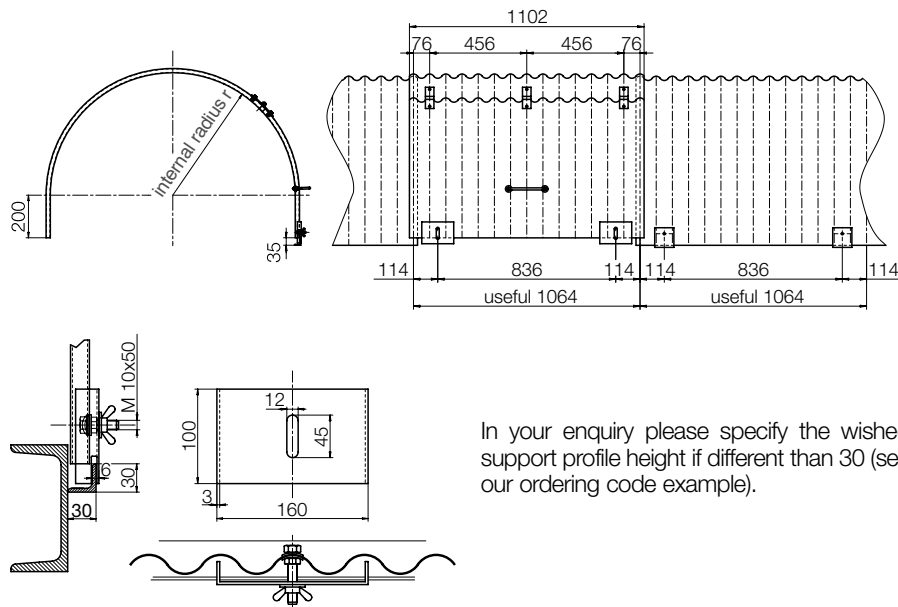

In your enquiry please specify the wished support profile height if different than 30 (see our ordering code example).

Caution: please check and confirm the straight side height so that the cover cannot interfere with transoms and rollers.

6 Covers

6.3.4 Dual full opening covers

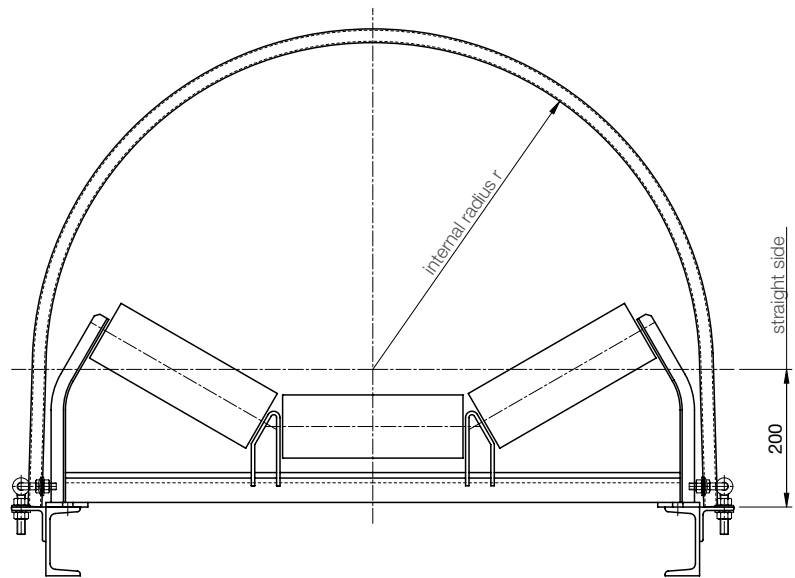
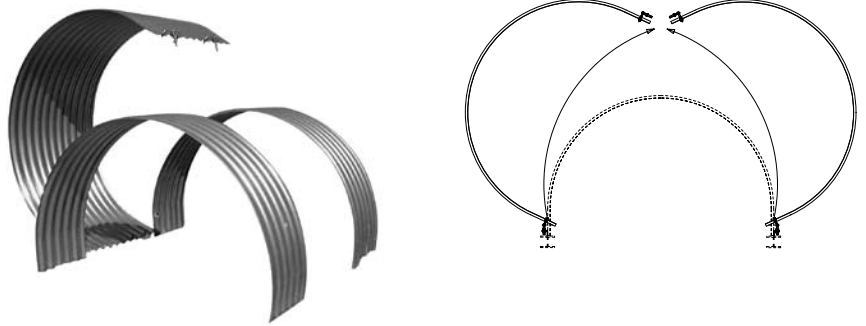

CPTA 1, 180° standard straight side 200 mm – dual full opening covers

Ordering code example for dual full opening covers:

	CPTA 1	1600/1025	180/1064	P200	FR	H30	Z35
type	_____	_____	_____	_____	_____	_____	_____
belt width/radius	_____	_____	_____	_____	_____	_____	_____
degrees/ length	_____	_____	_____	_____	_____	_____	_____
straight size (standard 200)	_____	_____	_____	_____	_____	_____	_____
with punching F	_____	_____	_____	_____	_____	_____	_____
fixing type R (see page 290)	_____	_____	_____	_____	_____	_____	_____
punching height	_____	_____	_____	_____	_____	_____	_____
material/covering (standard Z35 – see page 284)	_____	_____	_____	_____	_____	_____	_____

These covers are produced from galvanised sheet steel corrugated section 76/18 thickness 0,75 mm, suited to all belt conveyors with belt widths ranging from 400 to 1800 mm.

They belong to CPTA 1 series but they are characterised by a special fixing system, that allows their opening on both sides and makes belt inspection easier on both sides in the same conveyor point. All control operations and maintenance interventions to the plant result in the end to be made particularly easily.

Cover Type	Belt width mm	Radius r mm	Standard Length 1064 at 180° kg
CPTA 1	400	350	11.7
	500	400	12.9
	650	475	14.7
		550*	16.5
	800	575	17.0
		650*	18.8
	1000	675	19.5
		750*	21.3
	1200	800	22.5
		875*	24.3
	1400	900	24.9
	1600	1025	27.8
1800	1125	30.2	

(*) radius on request

Dimensions and mounting lay-outs

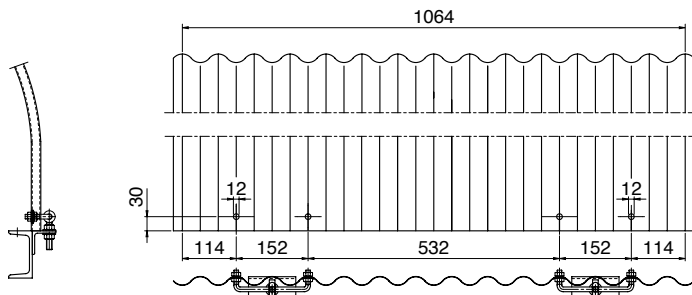

Composition with all dual full opening covers

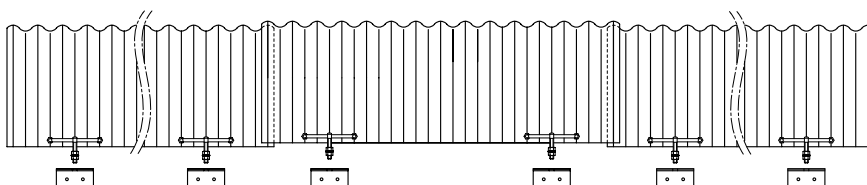

Composition with alternated fixed covers and dual full opening covers

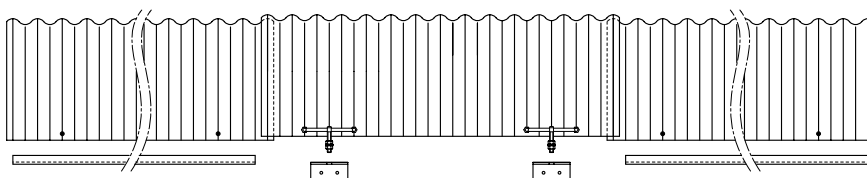

Fixing accessories

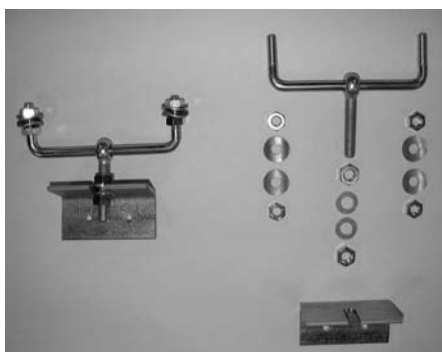

Fixing with hinges type R

The standard supply includes the following galvanised components:

- 1 hinge
- 4 nuts M10
- 4 washers
- 2 nuts M12
- 2 flat washers
- 1 bracket 50x50x100

Quantity to be ordered:
4 sets for each cover
Ordering code: CPTA, R

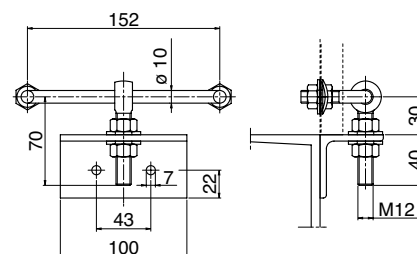

6 Covers

6.3.5 Removable covers



Ordering code example:

CPTA 1 1200/800 180/1064 P200 FM H30 Z35

type |
 belt width/radius |
 degrees/ length |
 straight size
 (standard 200) |
 with punching F |
Execution M (in 2 parts) |
 punching height |
 material/covering
 (standard Z35 – see page 284) |

Note: the supply for each cover includes N. 2 parts 90° and 2 handles with related nuts, all galvanised.

Fixing accessories: For each cover 180° we have to consider **N. 2** fixing accessories **type C** with stainless steel straps; see page 293.

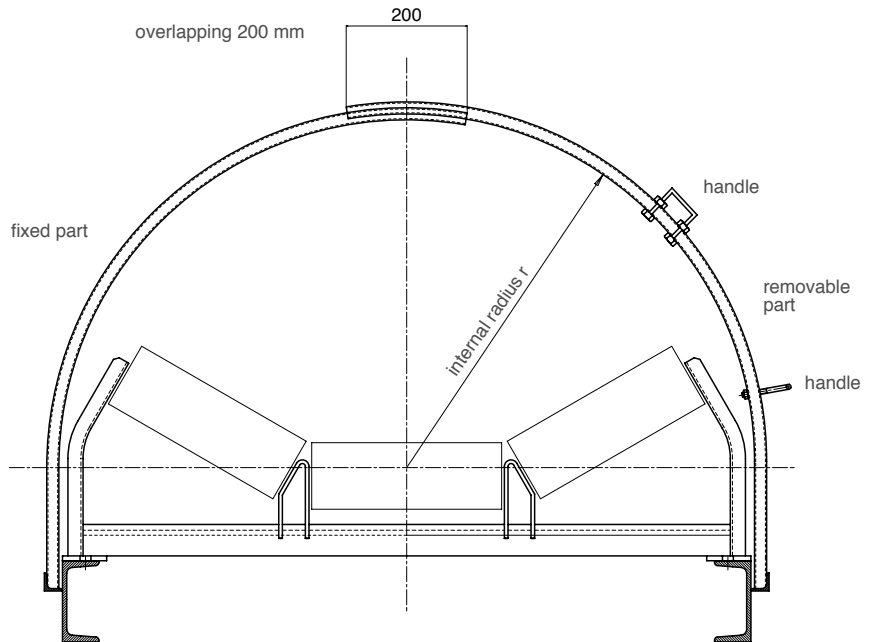

The best solution for **ergonomics and safety.**

Improved ergonomics for belt & idler inspection.

The removable part, equipped with 2 handles, is **easily disassembled** (the fixing is done with 2 straps).

More safety in comparison with other systems equipped with hinges, in order to avoid any risk to the operators.

Easy assembly.

Possible lock-up.

For a better visibility of the idlers sets we suggest the following lay-out:

1 cover - width 304 mm alternated to 1 removable cover - width 1064 mm.

Cover Type	Belt width mm	Radius r mm	Standard Length 1064 at 180° kg
CPTA 1	400	350	13.20
	500	400	13.39
	650	475	16.20
		550*	18.00
	800	575	18.59
		650*	20.39
	1000	675	21.00
		750*	22.79
	1200	800	23.99
		875*	25.80
	1400	900	26.40
1600	1025	29.39	
1800	1125	31.79	

(*) radius on request

6 Covers

6.3.6 Fixing accessories

The fixing system is designed for a quick positioning and a simple removal of the covers to allow the inspection of the idler sets and the conveyor belt.

Covers will be supplied:

- **with punching** for a fixing bolts, hooks and brackets;
- **without punching** for a fixing by stainless steel straps.

Fixing with galvanised hooks type G

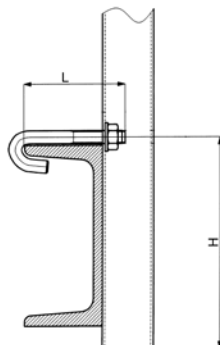

The set is composed by:

- 1 hook M8
- 1 nut M8
- 1 washer

Quantity to be ordered: 4 for each cover.

Ordering code:

CPTA, LG, 60

CPTA, LG, 70

CPTA, LG, 80

The values 60, 70 and 80 represent the length "L" of the hook.

At the order time you should determine dimension "H" too.

Fixing with galvanised bolts type B

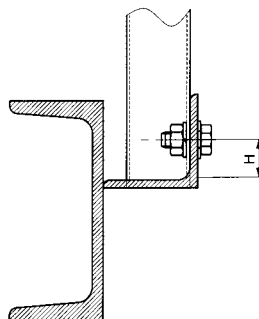

The set is composed by:

- 1 screw M8x20
- 1 nut M8
- 1 galvanised washer

Quantity to be ordered: 4 for each cover.

Ordering code: CPTA, BU

At order time you should determine dimension "H" for the punching.

Fixing with bracket type S

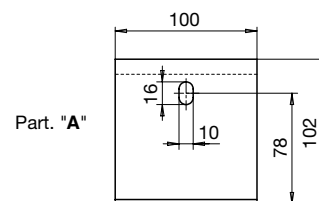
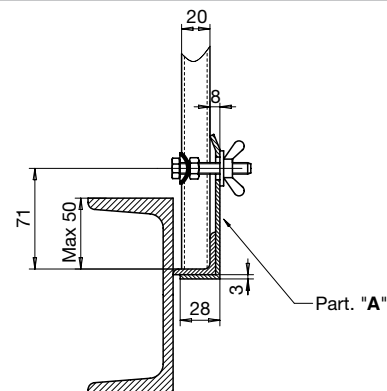

Details of the components

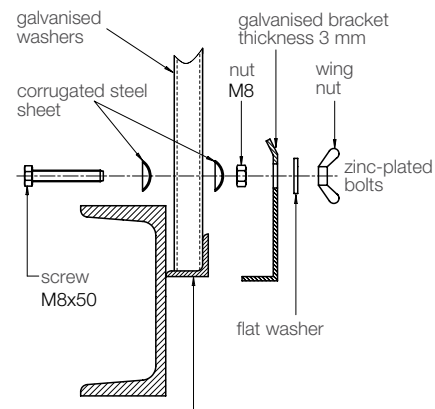

suggested support profile dimensions 30x30x4 (not supplied)

The standard supply includes:

- 1 bracket 100x100x3
- 1 screw M8x40
- 1 nut M8
- 1 wing nut
- 2 galvanised washers
- 1 flat washer

Quantity to be ordered:

- for belt width up to 800 = 2 for each cover
- for belt width up to 1000 and above = 4 for each cover

Ordering code: CPTA, ST.



6 Covers

Fixing with STAINLESS STEEL straps and hooks type C

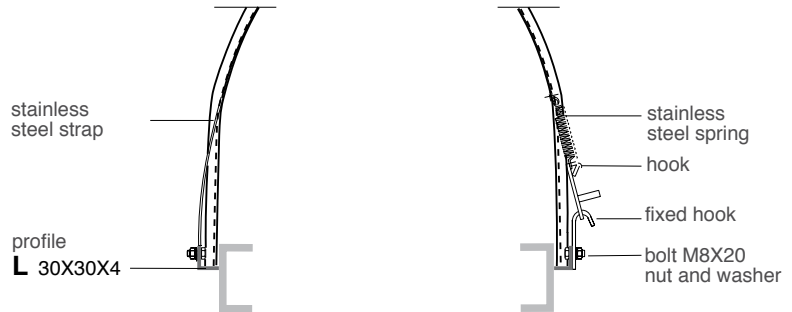

Each cover must be fixed by a stainless steel strap of 20 mm width and 0,6 mm thickness.

The steel strap is positioned on top of the section in the lower corrugation.

As shown in the figure and in relation to the section length, the steel strap is positioned and fixed as follows:

- on one side in the angle section drilled to accept bolts and washers M8x20.
- on the other side and in the identical position with a hook fixed to the angle section with a nut and washer M8x20.
- when mounting the stainless steel straps

must be cut at the right dimension and punched.

The standard supply includes:

- 1 strap with stainless steel spring and galvanised hook
- 1 fixed galvanised hook
- 2 galvanised bolts M8x20
- 2 galvanised washers

Width	Nr. of accessories for covers CPTA 1 and CPTA 2	Ordering code of the accessories for removable covers	Ordering code of the accessories for the fixing of CPTA cover
400	1	2	CPT/1F 400 (strap 15020018 – length 2200)
500	1	2	
650	1	2	
800	1	2	
1000	1	2	CPT/5F 1001 (strap 15020040 – length 3200)
1200	2	2	
1400	2	2	
1400	2	2	

Fixing with stainless steel ring hooks type A



It is possible to use stainless steel ring hooks, plates and stainless steel springs on both sides.

Hooks, plates, springs and straps must be ordered separately, stating the wished quantity. Advantages: no punching of the support profile. All the components are completely in stainless steel – anticorrosion. At order time for the related covers please specify the height "H" for punching.

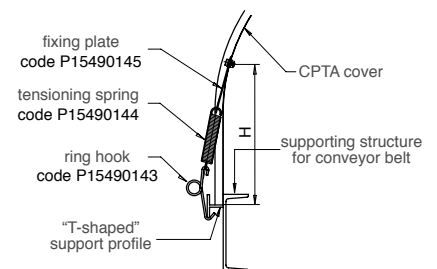



6 Covers

6.3.7 Ventilated covers

Ventilated covers are specifically meant for **hot environments** and conditions in which **hot material is handled**.

This system grants a good air circulation under the cover, thus decreasing the belt temperature and its hardness, so making its life longer.

These covers reduce the powder suspension in the air and the possible risks of explosion.

They are an excellent solution against corrosion problems in case of close and very wet environments.

Ventilated covers reduce and eliminate condensation.

The fixing components are the same as for standard covers.

The mounting is modular, namely: 1 ventilated cover every 2 covers or every 3 covers etc...

In order to ensure no ingress of water the covers must be overlapped by at least two waves.



6.3.8 Covers with hinged inspection door

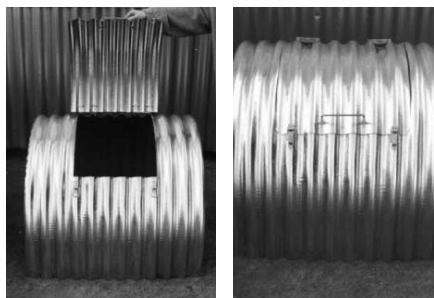

Dimensions for the opening window w. 415 x h. 540 mm or on request.

The cover opening is made through a hinged inspection door with handle.

The fixing is with steel hinges and fast locks.

The hinges, the locks and the handle are mounted on the hinged inspection door and positioned on the side where they can be easily reachable for the operators working at the conveyor.

The mounting of the hinged inspection door is done at the same time of the mounting of the covers on the conveyor.

The covers are supplied with punching for the door assembly.

6 Covers

6.3.9 CPTA 4 “Walkway”

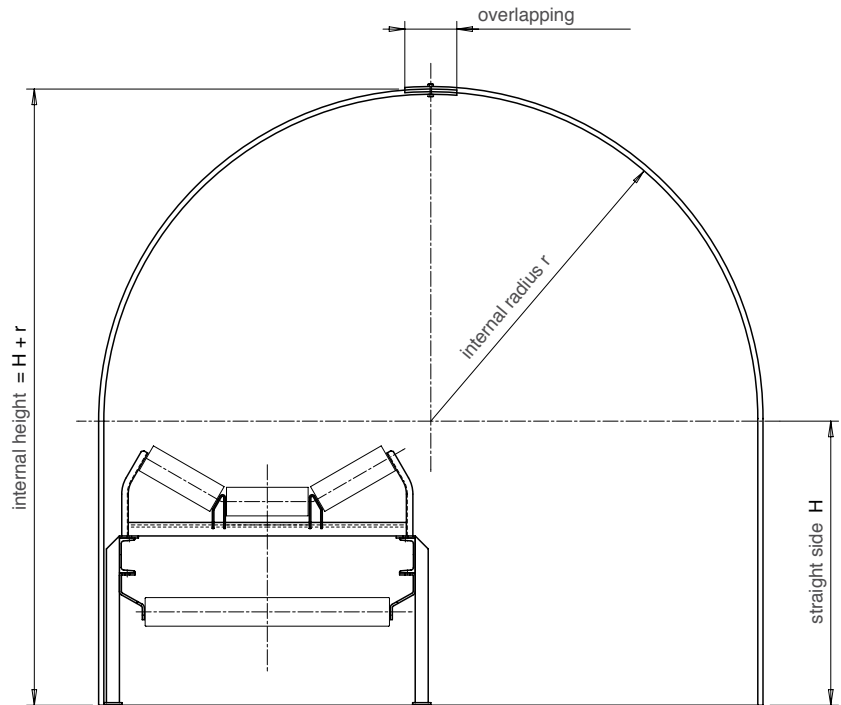

Covers are supplied in 2 pieces.
Standard pitch.
Maximum radius 1750 mm.

Dimensions on request:

When you send us your enquiry, please supply the following details:

- opening $2 R$
- straight side H
- lay-out for ground positioning
- lay-out for “suspended” positioning (in this case please specify the framework section)
- environmental conditions and wind max. force

NOTE: The fixing brackets for sheet steel covers (on the ground or fixed to the framework) are not part of our supply but we can suggest to you their shape (in any case we will provide the fixing dimensions).

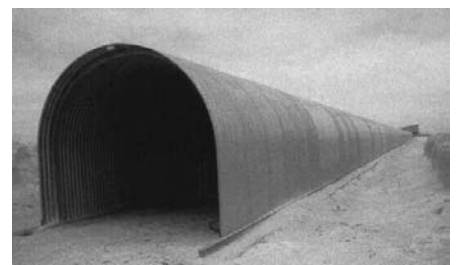
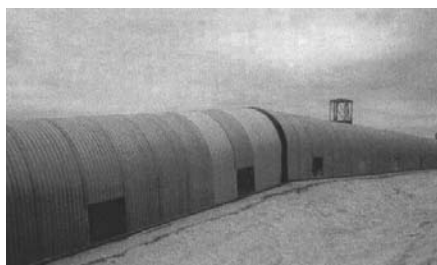

6 Covers

6.3.10 CPTA 6 Roof covers



Standard length.

Details to be specified:
Inflection (F)
Chord (C)

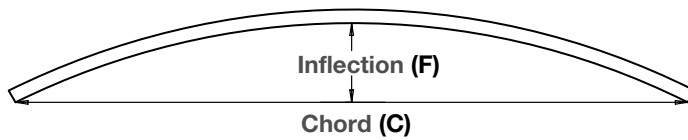

Possible fixing accessories for covers type 6
(not part of our supply).

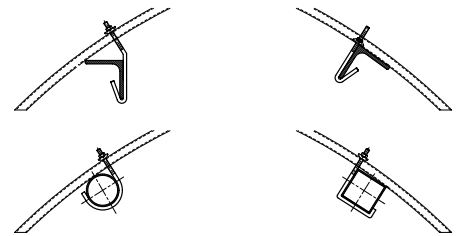

Applications

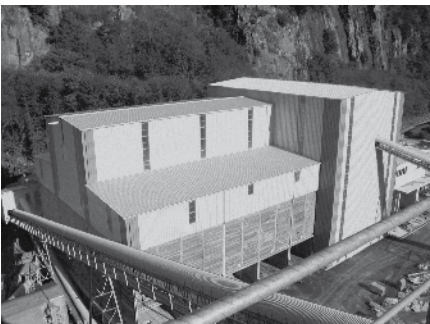
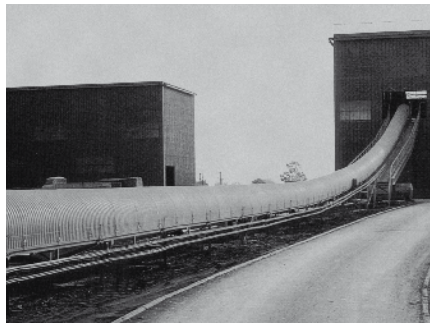

6 Covers

6.4 Covers series CPT in PVC

Plastic covers, made of preformed anti-shock, neutral colour, transparent PVC. Thanks to the characteristics of the material, they are light, transparent, anti-corrosive and with a smooth surface. Above all they are easy to adapt to any conveyor.

Apart from their resistance to corrosion they are classified "NON FLAMMABLE" DIN 4102.

Notwithstanding this property of self-extinguishing, the limit to the use of PVC covers in hot areas should not exceed 65°C.

PVC covers are produced in sections by heat forming sheets into "greek style" corrugations with profile and dimensions available to suit the most common belt widths.

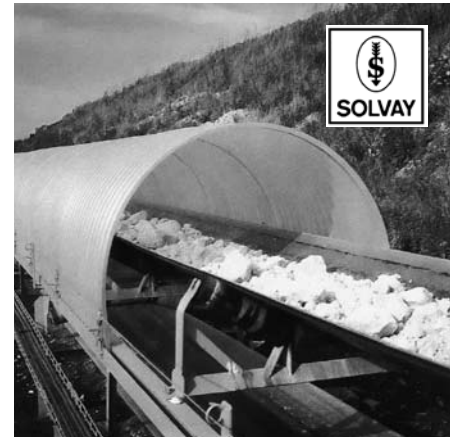

Greek module	Sketch of profile	Total length mm	Corrugations n.
70/18		1090	15 e 1/2

The mechanical properties of the belt covers are summarised in the following table.

Characteristics	Standards	Units	Values for colors Translucent
Mass per unit density	ISO R1183/NFT 51063	Kg/dm ³	1.39
Flexibility elasticity modulus	ISO R178/NFT 51001	MPa	3000
Traction elongation modulus	ISO R527/NFT 51034	%	80/85
Traction impact resistance from -20°C to 23°C	DIN 53488	kJ/m ²	>=300
Vicat point (49N)	ISO R306/NFT 51021	°C	79
Fire rating	NF 92507		M1
Thermal conductivity	DIN 52610	W/ml°C	0.14
Thermal expansion coefficient from -30°C a +30°C	ASTM D696	10 ⁻⁶ mm/mm°C	68.5
Light transmission	ASTM D1494	% compared to air	>=62
Weight according to profiles		kg/m ²	>=1.95
Anti-UV treatment		Grade from 0 to 20 (0 = no protection)	16

6 Covers

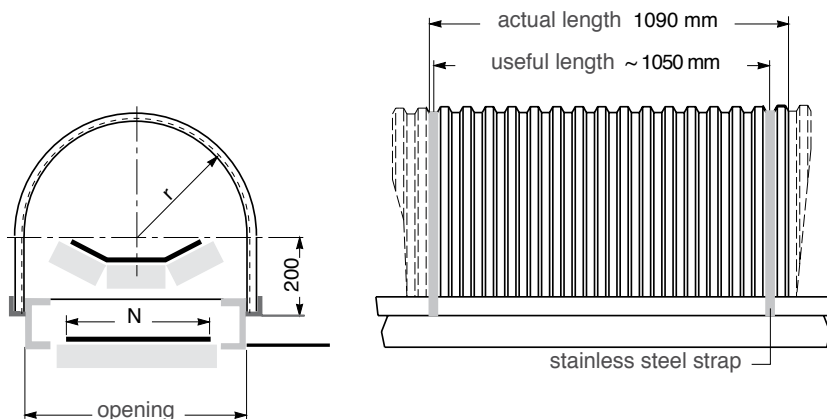

Cover Type	Belt width mm	Opening mm	Radius r mm	Development straights mm	Weight kg	Fixing accessories*	Nr. of accessories per cover
CPT 1	400	700	350	1500	3.6	CPT 1F 400	1
2	500	800	400	1660	4.0		1
3	650	950	475	1890	4.5		1
4	800	1150	575	2200	5.3		2

(*) Fixing accessories

*type CPT 1-2-3

- 1 Stainless steel strap and spring with galvanised hook
- 1 Fixed galvanised hook
- 2 Bolts M8x20 cadmium plated
- 2 Washers cadmium plated

*type CPT 4

- 2 Stainless steel straps and spring with galvanised hook
- 2 Fixed galvanised hooks
- 4 Bolts M8x20 cadmium plated
- 4 Washers cadmium plated

Installation method

Each cover section must be fixed by a stainless steel strap of 20 mm width and 0,6 mm thickness.

The steel strap is positioned on top of the section in the lower corrugation. During the installation the stainless steel straps must be cut and punched.

The last section of each conveyor needs one supplementary set of accessories.

Example of ordering:

CPT 3, 650 quantity 5
plus fixing accessories
CPT 1F, 400 quantity 5

CPT 4, 800 quantity 3
plus fixing accessories
CPT 1F, 400 quantity 6

The steel strap is positioned and fixed as follows:

- a) on one side in the angle section drilled to accept bolts and washers M8x20.
- b) on the other side and in the identical position with a zinc plated hook fixed to the angle section with a bolt, nut and washer M8x20.

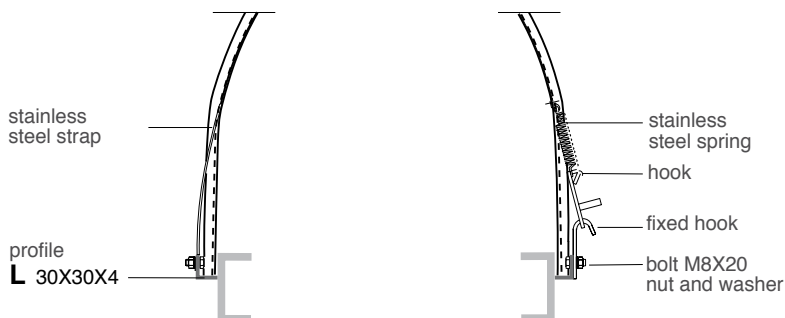

6 Covers

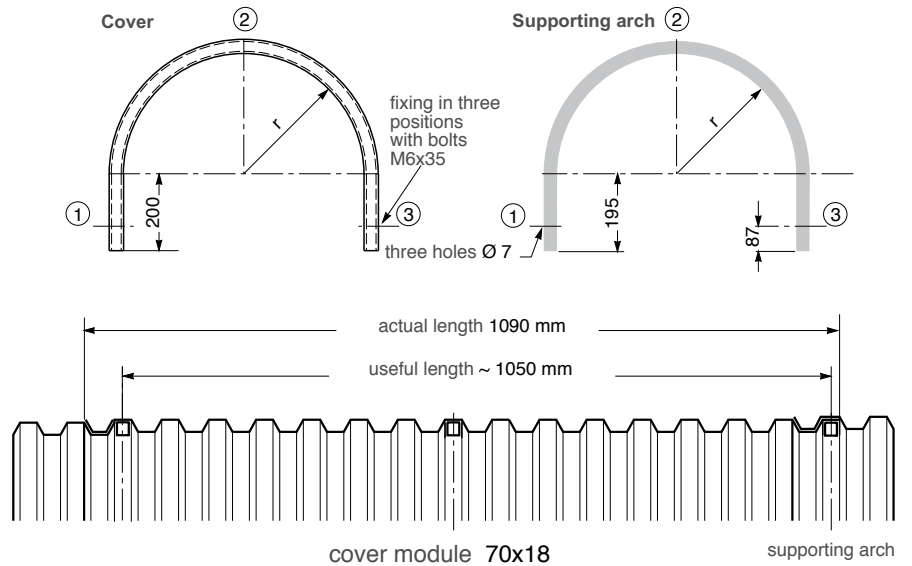

*type CPT 5-6-7

- 2 Arch in profile 20x20x2
- 6 Screws M6x35 cadmium plated
- 4 Nuts M6 cadmium plated
- 6 Washers cadmium plated
- 4 Locking nuts M6 cadmium plated
- 2 Fixing brackets 30x40 in zinc plated steel

Cover Type	Belt width mm	Opening mm	Radius r mm	Development straights mm	Weight kg	Nr. of accessories per cover	Fixing accessories with supporting arch*
CPT 5	1000	1350	675	2520	6.0	2	CPT 5F 1000
6	1200	1600	800	2910	7.0	2	6F 1200
7	1400	1800	900	3230	7.7	2	7F 1400

(*) fixing accessories

Installation method

For these covers it is necessary to position two supporting arches made from galvanised steel tube, one at the overlap junction and the other at the centre of each section.

The arches must be fixed and positioned at the junction of two covers as indicated in the figure.

The pre-formed PVC cover and the steel arch are both positioned in the angle section with brackets and fixed and locked by bolts, washers and wing nuts.

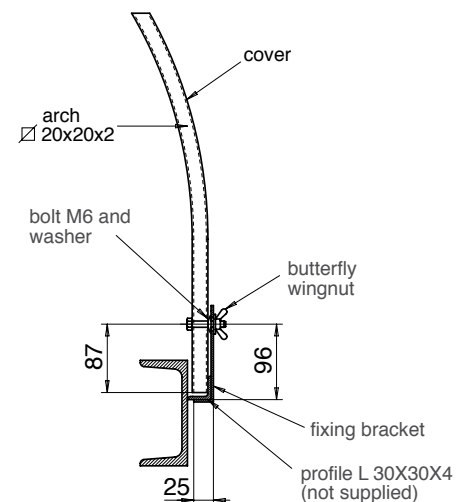

Example of ordering

CPT 5, 1000
plus fixing accessories
CPT 5F, 1000