

7 Impact bars

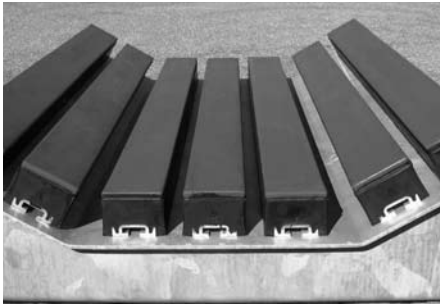

Rulmeca presents a new product to widen the range of components for belt conveyors: impact bars used at the loading point of the conveyor under the hopper. These impact bars utilise the important properties of two materials such as the low friction of polyethylene and a quality rubber to absorb shocks.

Benefits:

The impact bars, positioned under the loading points of the conveyor, prevent damage to the belt, keep the belt stable and avoid the spillage of the conveyed material.

Furthermore they ensure:

- less wear and risk of damage to the belt;
- limited extra power consumption as the belt runs on a polyethylene layer with a low friction coefficient;
- absorption of the shocks due to the impact of the material falling on the belt conveyor;
- more centralising effect and belt alignment;
- easy installation and reduction of maintenance time and costs;
- easy conversion from traditional impact systems;
- availability for any belt type and width and any inclination angle;
- the fixing bolts allow an easy and safe installation.

Note:

Impact rollers can be combined with bars, positioned within the central area, as they can further reduce friction.

Technical features:

Impact bars are produced and offered with the following technical features:

- polyethylene layer at high molecular density **PE HD 1000**;
- rubber cushion, hardness **45 Shore A**;
- aluminium profile AL 65;
- standard height **H = 75** (H = 50 on request);
- standard bar length **L = 1220** with **4** bolts (other lengths on request);
- for use with belts from 650 to 1600 mm;
- standard surface colour: **red**;
- fixing bolts with self-blocking nuts **M16**.

Ordering code example:

Impact bars H75 x 100 L=1220 45Sh. 4M16

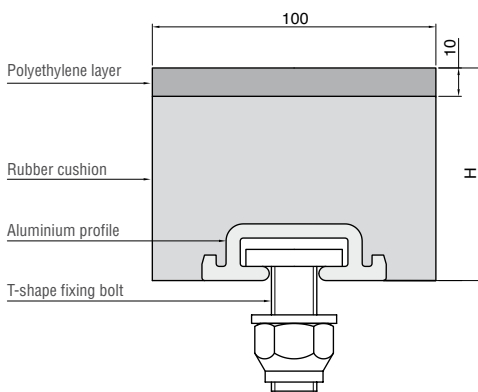

7 Impact bars

The supply of transoms to create an impact bar troughing effect in the loading points may be required.

They must comply with the dimensions of the carrying idlers on the belt conveyor, so, at the time of order please specify:

- shape and side inclination angle = 20°- 30°- 35° idlers;
- height to the top level of the central rollers;
- fixation or pitch distance of the idlers.

All dimensions are in mm.

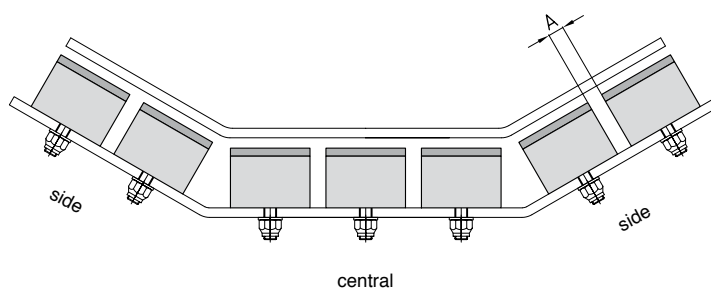

To be used for transoms with 20°- 30°- 35° inclination angle.

Suggested number of bars according to the belt width

Belt width mm.	Number of bars			Suggested distance 'A'	
	side	central	total	side	central
650	2+2	2	6	25	25
800	2+2	3	7	40	5
1000	3+3	3	9	25	25
1200	3+3	4	10	40	20
1400	4+4	5	13	20	5
1600	5+5	5	15	10	25

The distance "A" cannot be higher than 20 mm for rubber/steel cord belts and 40 mm for rubber/fabric belts.

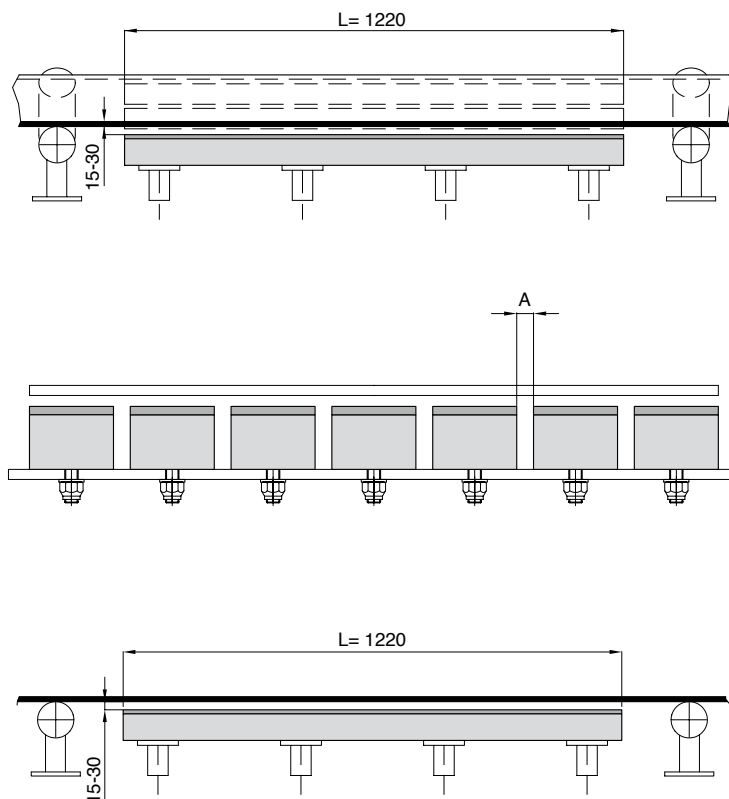

Impact bars must be installed to keep the clearance distance from the under-side of the belt to 15 mm for light applications and 30 mm for heavy applications.