



4.1 - Introduction

Pulleys are dimensioned according to the characteristics of each conveyor and may be designed to meet a great variety of construction methods.

For over 45 years Rulmeca has designed and manufactured pulleys, using materials of the highest quality in a production process employing advanced technology. This together with the application of the Quality Assurance system certified to ISO 9001:2008, contributes to the production of high quality products offering

dependable, long life performance in the field and appreciably reducing maintenance costs.

In the following drawings various arrangements of traditional belt conveyors are shown, with the pulleys numbered and described according to their function and position in the belt conveyor layout.

- | | |
|-------------------|-----------------------------|
| 1 - drive pulley | 4 - change direction pulley |
| 2 - return pulley | 5 - tension pulley |
| 3 - return pulley | 6 - snubbing pulley |

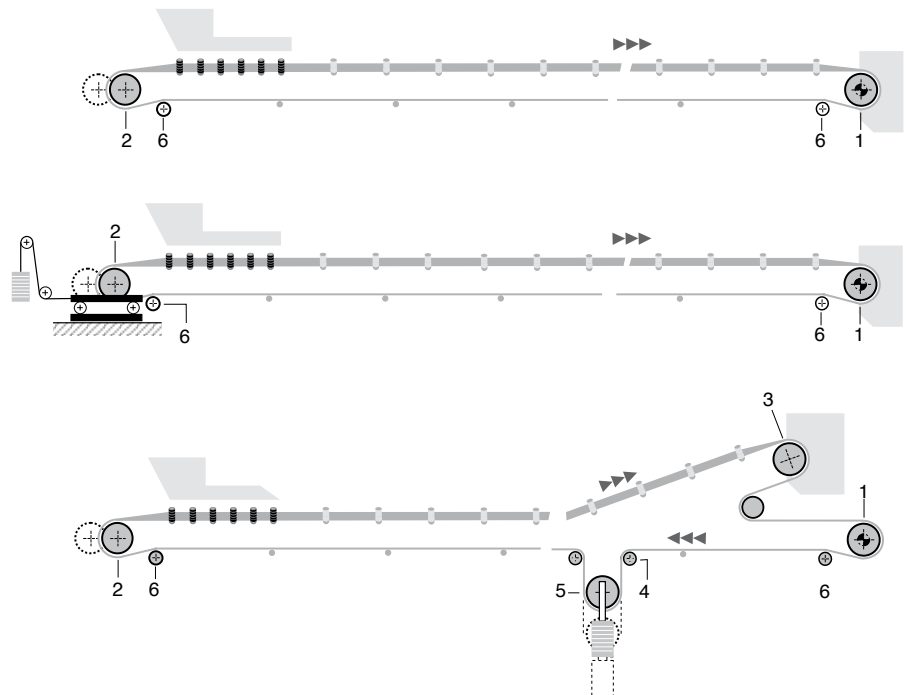

4 Pulleys

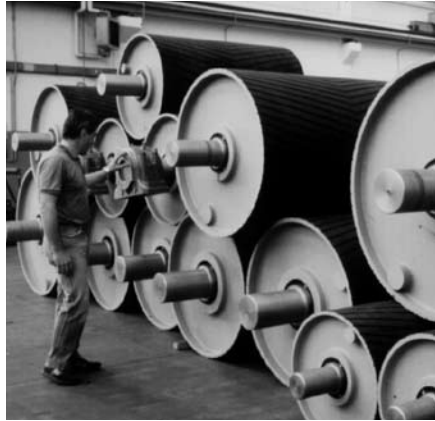

4.2 - Dimension of pulleys

According to the position that they occupy in a belt conveyor, the pulleys must withstand the forces imposed by both belt tension and conveyed load.

To be as efficient as possible both for replacement and for new installation, proper selection of pulleys requires the following data that allows the determination of the construction characteristics and dimensions.

The principal data necessary to design a pulley comprises the following:

- belt width;

- diameter of drum in relation to the belt type and characteristics;
- locking arrangement of the shaft to the pulley (locking ring, key, welding);
- position of pulley (drive, return, snub etc...);
- wrap angle of belt on pulley " α ";
- belt tensions T1, T2 or T3;
- distance between the supports and flange of the pulley " a_g ";
- type of lagging as required.

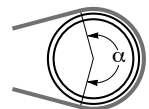
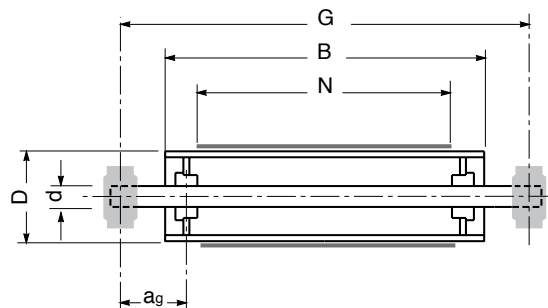



Limitation of deflection and rotation

After having sized the diameter of the shaft for various pulleys, the next selection check is to verify that the deflection of the shaft does not exceed allowable values.

In particular the deflection "ft" and the angle of inclination "αt" must respect the relationship:

4.2.1 - Shaft importance

Excessive deflection of the pulley shaft constitutes the major reason for failure of the drum structure.

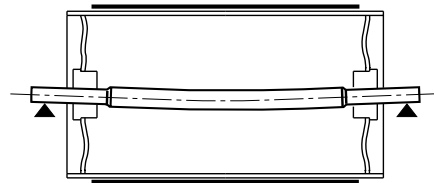

The correct sizing of the shaft is therefore of the greatest importance and must take into account an extra high safety factor.

$$f_{t \max} \leq \frac{C}{3000} \quad \alpha_t \leq \frac{1}{1000}$$

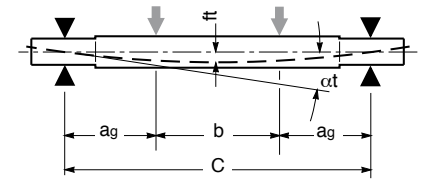

$$f_t = \frac{(Cpr/2)a_g}{24xE_xJ} [3(b+2a_g)^2 - 4a_g^2] \leq \frac{c}{3000}$$

$$\alpha_t = \frac{(Cpr/2)}{2xE_xJ} a_g (c - a_g) \leq \frac{1}{1000}$$

Where:

a_g = expressed in mm

E = modulus of elasticity of steel

(20600 [daN/mm²])

J = moment of inertia of shaft section

(0,0491 D⁴ [mm⁴])

Cpr = load on shaft [daN]



Upon the request for pulleys with characteristics and dimensions different from those indicated in this catalogue it is advisable to supply a dimensioned drawing of the pulley with the required features.

4 Pulleys

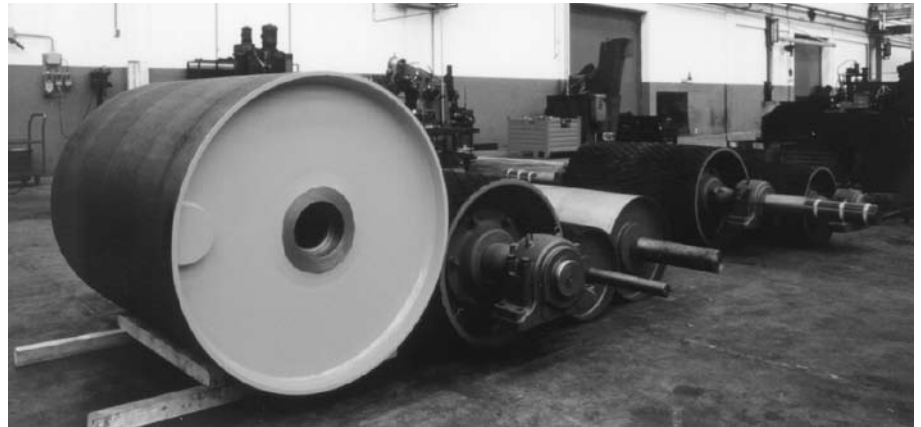

4.3 -General construction data

Rulmecca pulleys have been developed using a high degree of security in the dimensioning of the flanges, in the sizing and penetration of the welding and in the assembly between the shell, flange and hub.

Pulleys may be cylindrical or machine crowned to aid belt tracking.

Shafts are normally manufactured from high strength steel bar.



All components have been normalised after machining or welding, to allow internal stresses to be eliminated and to facilitate assembly and in turn disassembly, and also to eliminate reasons for cracking or deforming under load.

Continuous wire feeds are employed during the welding process, utilising an inert gas atmosphere, which guarantees the maximum uniformity and resistance of weld.

Both the welding system and the welders themselves are certified by the Italian Institute of Welding, according to norms of ASME.



4.3.1 - Types and designs

In this catalogue numerous designs and types of pulleys are proposed, to meet the great variety of uses.

To meet the duties of the severest working conditions they may be supplied rubber lagged.

Lagging prevents belt slippage (in particular when water is present) and increases the drive traction of the pulley.



1. Series USC-USF with clamping units

Clamping units allow compression shaft locking, using a system of screws and tapered sleeves, eliminating play and eccentricity ensuring the power transmission through an adequately sized torque transmission at the hub of the pulley.

Pulleys using this method of shaft locking are the most utilised today for their strength, simplicity of construction, assembly and maintenance.

The central part of the shaft, located in the clamping units of the pulley, with its major diameter with respect to the drum equipped with a key, guarantees a major mechanical resistance and the reduction of deflection underload.

Above all disassembly by unscrewing, typical in such a bush, is always smooth and easy even in the case of dirt build-up or rusting.

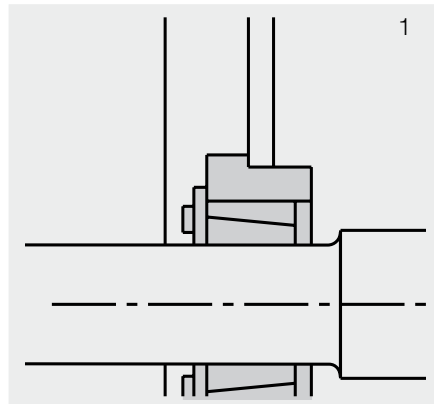

2. Series CUF with incorporated bearings

Essentially a simplified construction, using radial ball bearings in a moveable housing designed into the pulley itself.

This system lends itself to be used together with the screw tensioning unit. Normally used as tail pulleys for small or medium loaded conveyors, and naturally only for idler type pulleys (not driven).

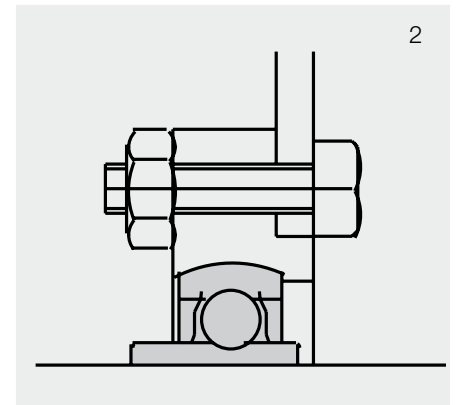

Other types of special pulleys or according to drawings can be supplied upon request as listed in page 264.

4 Pulleys

4.4 - Order code

Pulleys are identified according to the following characteristics:

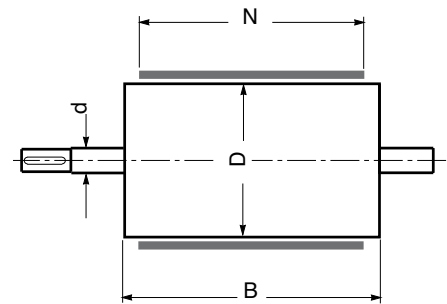

	USC	-630	-750	-40	YA	RA	12
Example:							
Pulley series							
Diameter of shell							
Length "B" of shell							
Diameter of shaft (corresponding to the bearings)							
System of end cap finish **							
Lagging *							
Thickness of lagging							

* - the lagging must be specified as: the form, the thickness and in the case of lagging cut as herringbone, the rotational sense of the pulley as seen from the drive side, as the following list:

- R - lagged in smooth rubber
- RR - lagged in rubber diamond pattern
- RA - lagged in rubber herringbone pattern, sense anti-clockwise
- RO - lagged in rubber herringbone pattern, sense clockwise

The type of standard rubber supplied for the lagging: hardness 60 or 70 Shore A, colour black, anti-abrasive.

On request it is possible to supply different hardnesses or types.

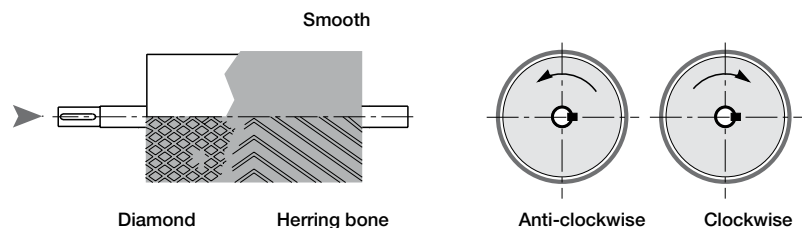

** System of pulley end cap finish

Symbol	Description of treatment
YA	painted with antirust primer, zinc phosphate based 40 micron, colour grey
YB	sandblasted SA 2,5 + epoxy rich-zinc primer 70 micron, colour grey
YC	sandblasted SA 2,5 + epoxy rich-zinc 40 micron + epoxy enamel 60 micron, colour grey RAL 7035
YS	special paint finish as requested (specify)

4.5 - Programme

Pulleys type	Series	Design
USC	drive pulleys	with clamping units
USF	idler pulleys	with clamping units
CUF	idler pulleys	with incorporated bearings
TDV	screw tension units	simple
Special PULLEYS		



4 Pulleys

Series USC drive with clamping units

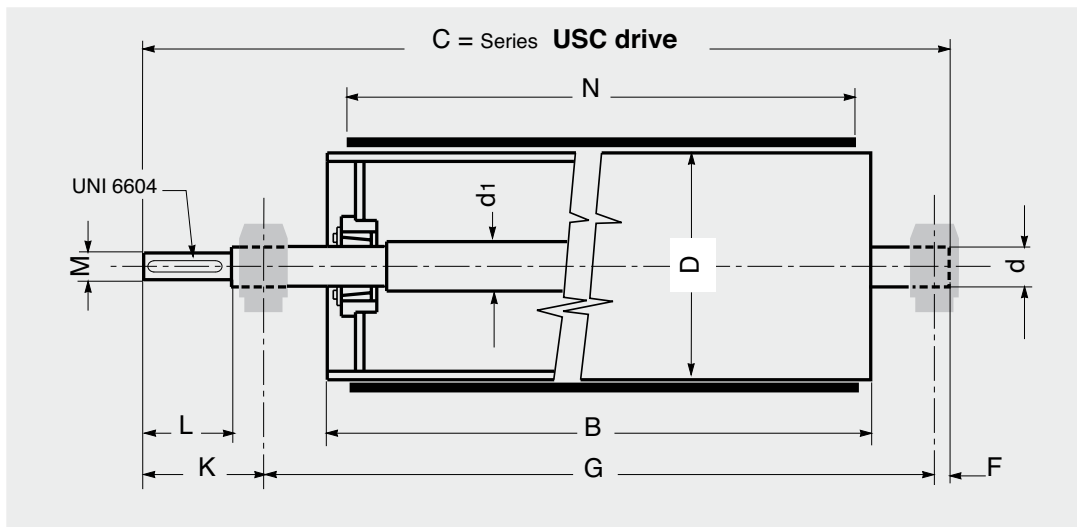

4.5.1 - Drive pulleys with clamping units

On request pulleys may be supplied with characteristics and dimensions different from those indicated in the table or using the customer's drawing.

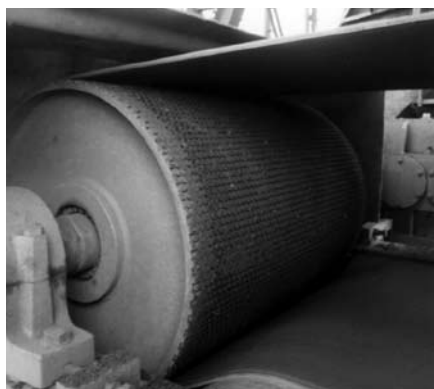

For the order code of execution and lagging see page 256.

The weight stated on the list is referred to the complete pulley without supports which can be supplied upon request.

Pulley with dimensions according to standard NFH 95330.

Example of ordering
standard design
USC,800,1150,100,YA,RR,12



Series **USC** drive pulleys with clamping units

Belt width N mm	Pulley type	D mm	B	d	C	d1	M m6	L	K	F	G	Weight Kg
400	USC	190	500	40	830	45	38	80	145	25	660	34
		270	500	40	830	45	38	80	145	25	660	46
		320	500	40	830	45	38	80	145	25	660	52
500	USC	190	600	40	930	45	38	80	145	25	760	38
		270	600	40	930	45	38	80	145	25	760	52
		320	600	40	930	45	38	80	145	25	760	59
		400	600	50	990	55	48	110	180	30	780	94
		520	600	50	990	55	48	110	180	30	780	126
650	USC	270	750	40	1080	45	38	80	145	25	910	62
		320	750	50	1140	55	48	110	180	30	930	79
		400	750	50	1140	55	48	110	180	30	930	111
		520	750	65	1190	70	60	140	225	35	930	162
		620	750	65	1190	70	60	140	225	35	930	194
800	USC	320	950	50	1350	55	48	110	180	30	1140	95
		400	950	50	1350	55	48	110	180	30	1140	133
		520	950	65	1400	70	60	140	225	35	1140	191
		620	950	80	1450	85	70	140	235	45	1170	254
		800	950	80	1450	85	70	140	235	45	1170	417
1000	USC	400	1150	65	1600	70	60	140	225	35	1340	176
		520	1150	80	1650	85	70	140	235	45	1370	250
		620	1150	80	1650	85	70	140	235	45	1370	290
		800	1150	100	1725	105	90	170	280	55	1390	521
1200	USC	520	1400	80	1910	85	70	140	235	45	1630	307
		620	1400	80	1910	85	70	140	235	45	1630	361
		800	1400	100	1985	105	90	170	280	55	1650	659
1400	USC	620	1600	100	2185	105	90	170	280	55	1850	458
		800	1600	100	2185	105	90	170	280	55	1850	718



4 Pulleys

Series **USF** idler with clamping units

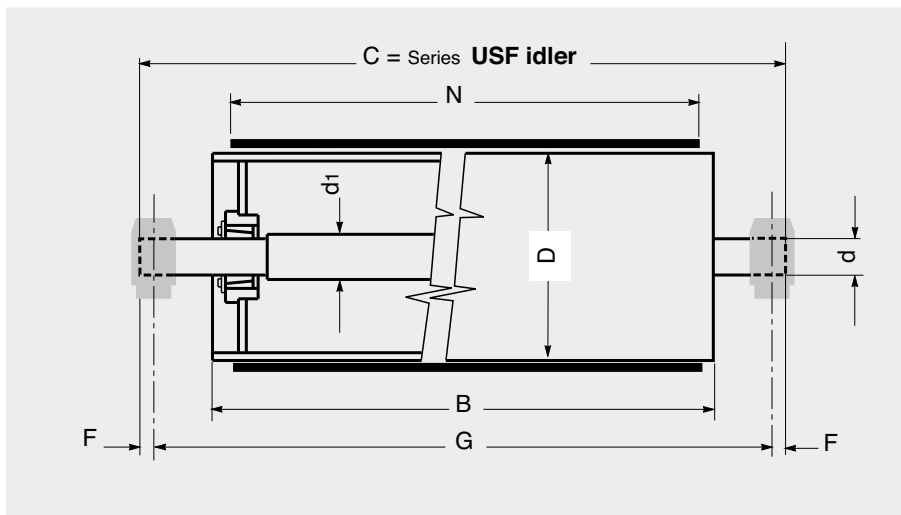

4.5.2 - Idler pulleys with clamping units

On request pulleys may be supplied with characteristics and dimensions different from those indicated in the table or using the customer's drawing.



For the order code of execution and lagging see page 256.

The weight stated on the list is referred to the complete pulley without supports which can be supplied upon request.

Pulley with dimensions according to standard NFH 95330.

Example of ordering
standard design
USF,620,750,50, YA,RO,10



Series USF Idler pulleys with clamping units

Belt width N mm	Pulley type	D mm	B	d	C	d1	F	G	Weight
									Kg
400	USF	190	500	40	710	45	25	660	32
		270	500	40	710	45	25	660	45
		320	500	40	710	45	25	660	51
500	USF	190	600	40	810	45	25	760	37
		270	600	40	810	45	25	760	51
		320	600	40	810	45	25	760	58
		400	600	40	810	45	25	780	85
		520	600	50	840	55	30	780	124
650	USF	270	750	40	960	45	25	910	61
		320	750	40	960	45	25	910	69
		400	750	40	960	45	25	910	100
		520	750	50	990	55	30	930	144
		620	750	50	990	55	30	930	176
800	USF	320	950	40	1170	45	25	1120	83
		400	950	40	1170	45	25	1120	121
		520	950	50	1200	55	30	1140	170
		620	950	65	1210	70	35	1140	223
		800	950	65	1210	70	35	1140	387
1000	USF	400	1150	50	1400	55	30	1340	153
		520	1150	65	1410	70	35	1340	216
		620	1150	65	1410	70	35	1340	256
		800	1150	80	1460	85	45	1370	465
1200	USF	520	1400	65	1670	70	35	1600	270
		620	1400	65	1670	70	35	1600	324
		800	1400	80	1720	85	45	1630	599
1400	USF	620	1600	80	1920	85	45	1830	391
		800	1600	80	1920	85	45	1830	654

4 Pulleys

Series

CUF idler

with incorporated bearings

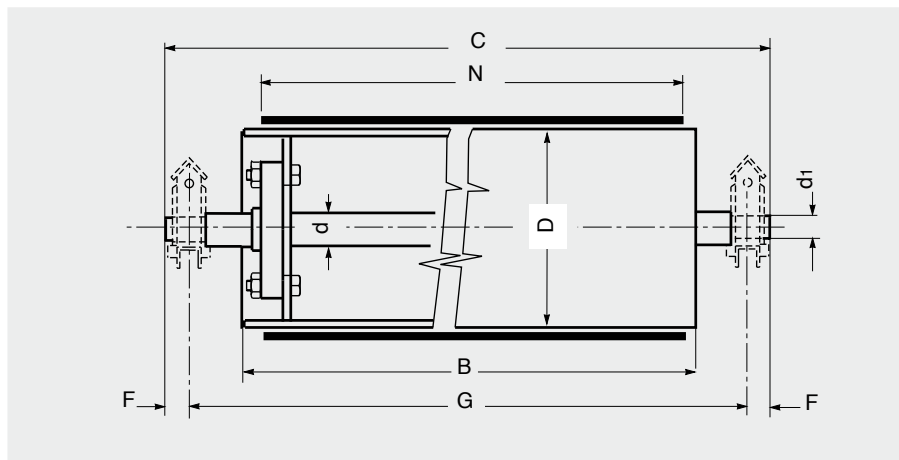

4.5.3 - Idler pulleys with incorporated bearings

Essentially a simplified construction, using radial ball bearings in a moveable housing designed into the pulley itself.

This system lends itself to be used together with the screw tensioning unit. Normally used as tail pulleys for small or medium loaded conveyors, and naturally only for idler type pulleys (not driven).

This type of pulley and tension units TDV are suggested for use on belt conveyors length not up to 50 m.

2

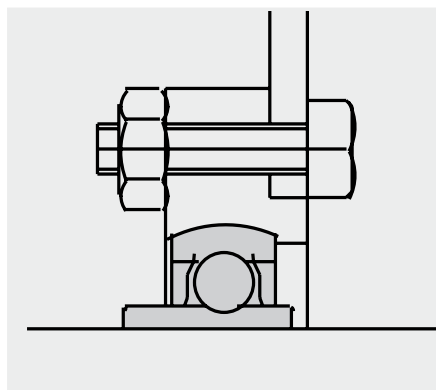

On request pulleys may be supplied with characteristics and dimensions different from those indicated in the table, or using the customer's drawing.

Belt width mm	Pulley type	D mm	B	d	d1	F	G	C	Weight Kg	
400	CUF	190	500	40	38	30	760	820	28	
		270							36	
		320							44	
500	CUF	190	600	40	38	30	860	920	47	
		270		40					57	
		320		40					79	
		400		50					130	
650	CUF	270	750	40	38	30	1010	1070	50	
		320		40			38	1010	1070	61
		400		50			48	1050	1110	81
		520		60			58	1050	1110	136
800	CUF	320	950	40	38	30	1210	1270	75	
		400		50			48	1250	1310	105
		520		60			58	1250	1310	164
		620		70			68	1250	1310	197
1000	CUF	400	1150	50	48	30	1450	1510	123	
		520		60					58	176
		620		70					68	236

For the order code of execution and lagging see page 256.

tension units

TDV with screw

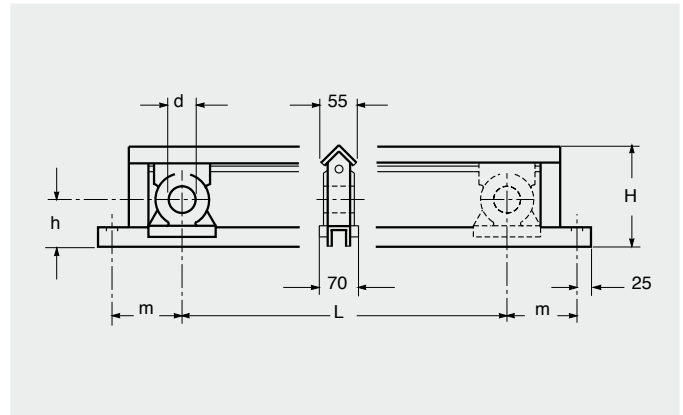

4.5.4 - Screw tension unit

Used only in combination with pulleys CUF with fixed shaft and internal bearings, in that a hole is positioned to accept a static shaft (the possibility of assembling external bearing supports has not been considered in these tension units)

The use is restricted only to the installation of the pulley at the tail of the belt conveyor of a length not more than 50 m, selecting the length of movement in relation to the presumed belt stretch.

Over the above length it is advisable to use other types of tension units.



Tension unit type	d mm	L	h	m	H	Weight Kg
TDV 01	38	300	75	110	165	9
02		400				10
03		500				11
04		600				12
05		700				13
06		800				15
07		900				16
08		1000				17
TDV 21	48	300	85	120	185	11
22		400				12
23		500				13
24		600				14
25		700				15
26		800				17
27		900				18
28		1000				19
TDV 41	58	300	85	120	185	10.5
42		400				11.5
43		500				12.5
44		600				13.5
45		700				14.5
46		800				16.5
47		900				17.5
48		1000				18.5

4 Pulleys

4.5.5 - Special pulleys

Following specific requests and, if possible, a reference drawing provided by the customer, Rulmeca is able to manufacture different types of special pulleys such as:

Type 1 - pulleys with shaft-to-hub connection by means of key locking device (instead of clamping units).

These pulleys, of more traditional design, may have some limitation if compared to those pulleys having a shaft-to-hub connection by means of clamping units: lower shaft strength due to the reduced diameter in the centre and to the grooves for the keys.

Furthermore they have a lower centering precision between the shaft and the hubs and, in the frequent case of oxidation, the disassembly of the two parts can be very difficult if not impossible.

Type 2 - Pulleys with flanges directly welded to the shaft.

Type 3 - Pulleys without shaft, with flanges and stub axles.

These simplified types of pulleys are suitable only for light applications and should be used only for deviation, contrast or take up positions. Continuous service shaft substitution should not be foreseen for these pulleys.

For particular applications, where very wet materials are conveyed and the belt inner surface gets very dirty, special pulleys can be supplied such as:

Type 4 - squirrel cage pulleys

Type 5 - wing pulleys

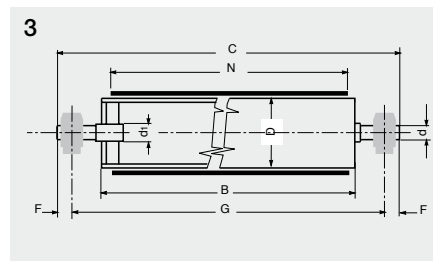
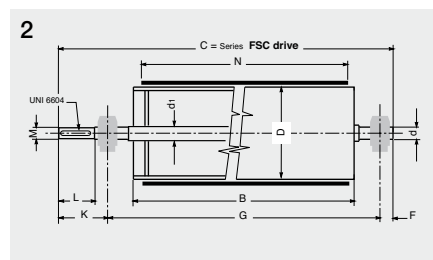
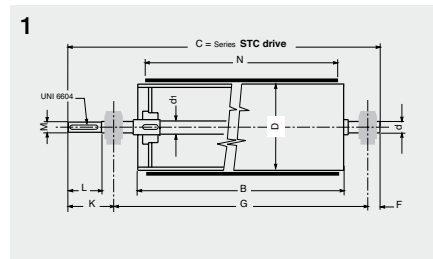
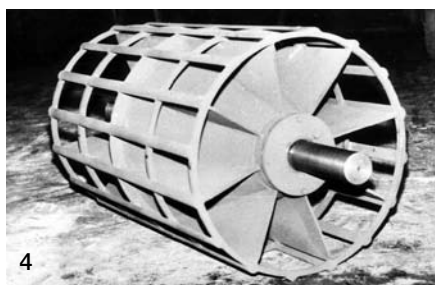

Pulleys according to other types and dimensions than those described in this catalogue can be quoted and manufactured if requested and provided that the customer submits a drawing.

