

2.6.2 - Return rollers with rings

The straight tracking of the belt may be compromised by the type of conveyed material, specially when this material is sticky and thereby adheres easily to the belt surface.

In this case, material is also deposited on the return rollers that support the belt, adding an irregular addition of scale to the roller itself.

As a consequence, not only wear and tear of the belt occurs, but forces are brought into play to move the belt away from its correct track.

Return rollers with spaced rubber rings contribute largely to eliminating the build up of scale that forms in certain conditions on the belt surface.

The rings are pointed, assembled at intervals, in the central part of the roller, where they have the scope to break up the scale which normally is present at the belt centre; meanwhile flat rings mounted in

groups at the extremities of the belt, support and protect the belt edges, also in cases of limited belt wandering.

Return rollers with rings should not be used as belt tensioning devices.

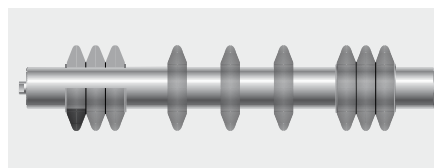

Arrangement G

Return rollers with pointed rings spaced in the central part and positioned in sets at the side. Used on belt conveyors of medium capacity.

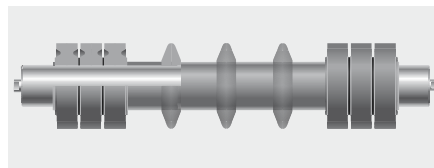

Arrangement L

Return rollers used on belt conveyors in high duty plant. They are provided with sets of flat rings, positioned at the roller extremities, and with pointed rings spaced in the central part of the roller.

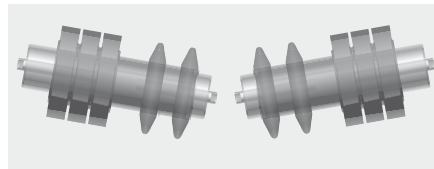

Arrangement C

Return rollers for return transom sets of "V" design format with base rollers from series PSV, with characteristic proportional dimensions to the requirements designed into large belt conveyors.

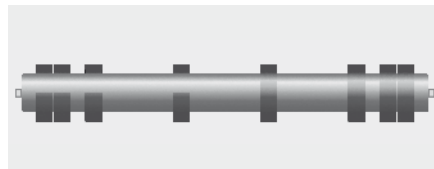

Arrangement with special flat rubber ring type B for pulp and paper and other industries.

The table indicates the types and diameters of standard rings and dimensions according to European norms.
On request special diameters and tube thicknesses may be supplied.

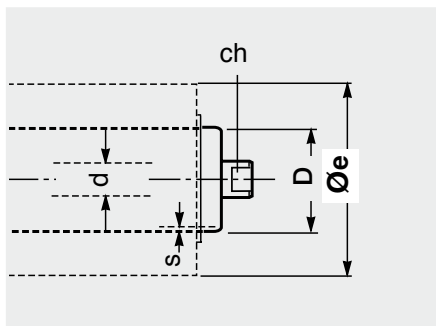

Programme of production of return rollers with rings

base roller type	D		Øe		spindle		bearing
	mm	s	mm	design	d	ch.	
RTL 1	60	2.0	108	NG	15	17	6202
	60	2.0	133	NG			
MPS 1	60	3.0	108	NG	15	17	6202
	60	3.0	133	NG			
PSV 1	63	3.0	108	NG	20	14	6204
	63	3.0	133	NG			
	63	3.0	108	NL, NC			
	89	3.0	133	NL, NC			
	89	3.0	159	NL, NC			
108	3.5	180	NL, NC				
PSV 2	89	3.0	133	NL, NC	25	18	6205
	89	3.0	159	NL, NC			
	108	3.5	180	NL, NC			
PSV 4	89	3.0	133	NL, NC	30	22	6206
	89	3.0	159	NL, NC			
	108	3.5	180	NL, NC			
PSV/7-FHD	108	3.5	180	NL, NC	40	32	6308



2 Rollers

series with rings

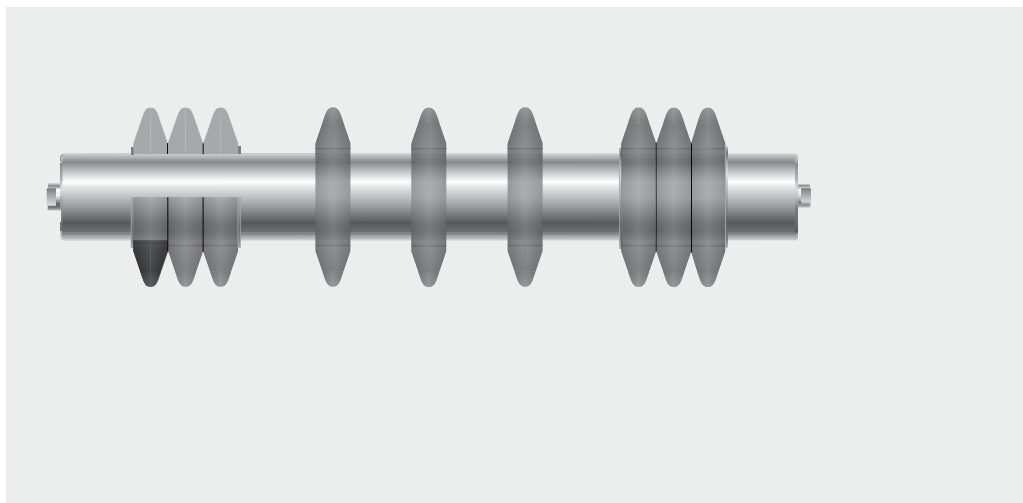

Øe 108 NG

Base roller:

RTL 1

D = 60;
spindle 15 ; d₁ = 20
bearing 6202
ch = 17

PSV 1

D = 63;
spindle 20; d₁ = 20
bearing 6204
ch = 14

MPS 1

D = 60;
spindle 15; d₁ = 20
bearing 6202
ch = 17

belt	roller							
	width mm			dimensions mm			weight Kg	rings n°
arrangements	B	C	A	RTL 1	MPS 1	PSV 1	total	
	300	380	388	406	2.7	3.4	5	
	400	500	508	526	3.2	4.1	5	
	500	600	608	626	3.8	4.8	5.9	6
	650	750	758	776	4.9	6.1	7.4	9
	800	950	958	976	6.0	7.4	9.0	10
	1000	1150	1158	1176	7.1	8.9	10.7	12
	1200	1400	1408	1426		10.4	12.6	13
	1400	1600	1608	1626			14.3	15

roller length C mm	rings				side central side		
	a mm	b	t	E	n°		
388	25	85	220	25	2	1	2
508	25	135	320	25	2	1	2
608	25	130	440	25	2	2	2
758	50	125	600	25	3	3	3
958	50	124	720	25	3	4	3
1158	50	115	905	25	3	6	3
1408	50	125	1100	25	3	7	3
1608	50	120	1300	25	3	9	3

Example of ordering
standard design
MPS1,15B,108NG,508

for special designs
see pages 80-81

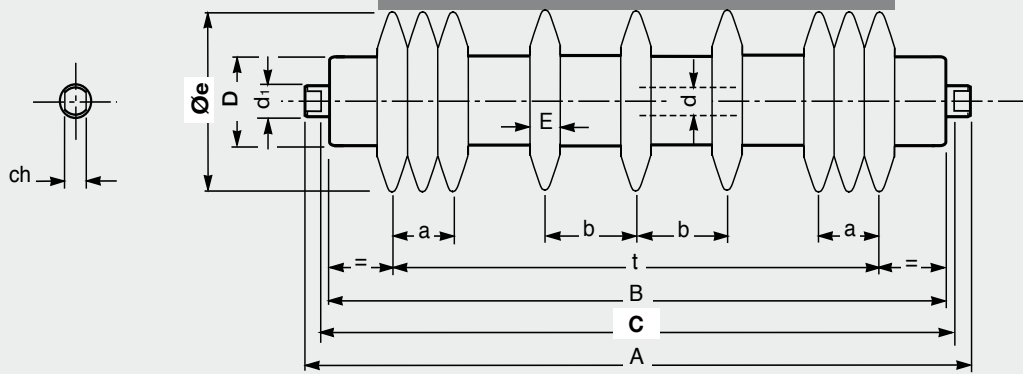

Øe 133 NG

Base roller:

RTL 1

D = 60;
spindle 15; d₁ = 20
bearing 6202
ch = 17

MPS 1

D = 60;
spindle 15; d₁ = 20
bearing 6202
ch = 17

PSV 1

D = 63;
spindle 20; d₁ = 20
bearing 6204
ch = 14

belt	roller			weight			rings n°	
	width mm	dimensions mm		Kg				
arrangements		B	C	A	RTL 1	MPS 1	PSV 1	total
	300	380	388	406	3.8	4.4		5
	400	500	508	526	4.3	5.1		5
	500	600	608	626	5.1	6.0	7.1	6
	650	750	758	776	6.8	8.0	9.3	9
	800	950	958	976	8.1	9.5	11.1	10
	1000	1150	1158	1176	9.7	11.4	13.2	12
	1200	1400	1408	1426		13.2	15.4	13
	1400	1600	1608	1626			17.5	15
	1600	1800	1808	1826			19.7	17

roller length C mm	rings				side central side		
	a mm	b	t	E	n°		
388	30	100	260	30	2	1	2
508	30	120	300	30	2	1	2
608	30	115	405	30	2	2	2
758	60	120	600	30	3	3	3
958	60	120	720	30	3	4	3
1158	60	115	925	30	3	6	3
1408	60	125	1120	30	3	7	3
1608	60	120	1320	30	3	9	3
1808	60	115	1500	30	3	11	3

Example of ordering
standard design
PSV1,20F,133NG,758

for special designs
see pages 80-81



2 Rollers

series with rings

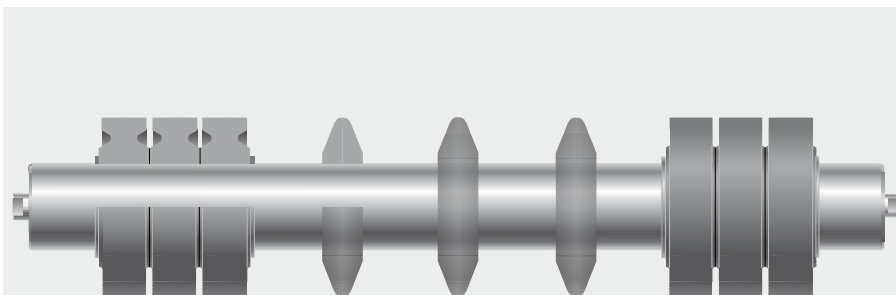

The two sets of flat rings are held in position by steel rings welded to the tube

Øe 108 NL

Base roller:

PSV 1

D = 63;
spindle 20; d₁ = 20
bearing 6204
ch = 14

belt	roller			weight Kg	rings n°	
	width mm	dimensions mm				
arrangements		B	C	A	PSV 1	total
300		380	388	406	4.6	5
400		500	508	526	5.6	6
500		600	608	626	6.4	7
650		750	758	776	7.6	8
800		950	958	976	9.6	10
1000		1150	1158	1176	11.3	12
1200		1400	1408	1426	13.2	13
1400		1600	1608	1626	15.3	15

belt	roller	rings					side n°	central	side
		width mm	length mm	a mm	b	t			
300	388	90	86	342	25	45	2	1	2
400	508	90	90	442	25	45	2	2	2
500	608	90	93	542	25	45	2	3	2
650	758	90	104	690	25	45	2	4	2
800	958	135	117	840	25	45	3	4	3
1000	1158	135	112	1039	25	45	3	6	3
1200	1408	133	123	1239	25	45	3	7	3
1400	1608	135	118	1435	25	45	3	9	3

Example of ordering
standard design
PSV1,20F,108NL,1158

for special designs
see pages 80-81

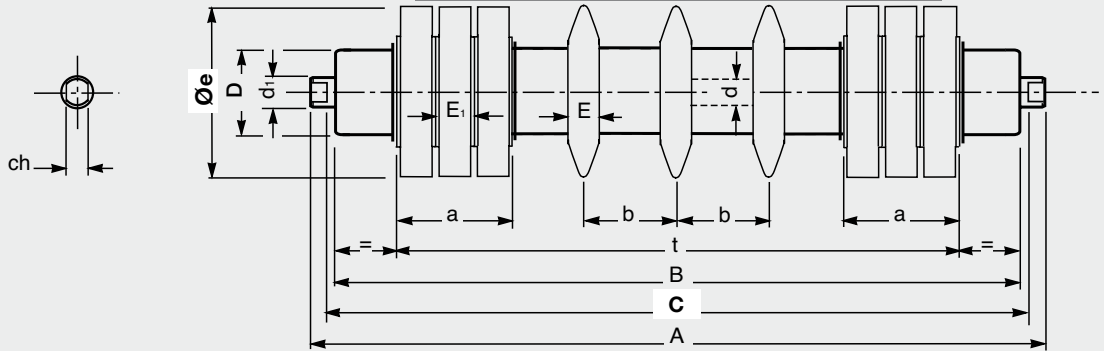

Øe 133 NL

Base roller:

PSV 1

D = 89;
spindle 20; d₁ = 20
bearing 6204
ch = 14

PSV 2

D = 89;
spindle 25; d₁ = 25
bearing 6205
ch = 18

PSV 4

D = 89;
spindle 30; d₁ = 30
bearing 6206
ch = 22

Example of ordering
standard design
PSV2,25F,133NL,1608

for special designs
see pages 80-81

belt width mm	roller dimensions mm			weight Kg			rings n°
	B	C	A	PSV 1	PSV 2	PSV 4	total
500	600	608	*	8.4			9
650	750	758	*	10.0	11.6		10
800	950	958	*	12.2	14.1	16.3	12
1000	1150	1158	*	14.6	16.8	19.3	14
1200	1400	1408	*	17.3	19.6	22.6	15
1400	1600	1608	*	19.3	22.0	25.3	16
1600	1800	1808	*	21.4	24.4	28.1	17
1800	2000	2008	*		26.8	30.8	18
2000	2200	2208	*			33.5	19

* in relation to the choice of base roller

belt width mm	roller length mm	roller					rings		
		a mm	b mm	t mm	E mm	E ₁ mm	side n°	central n°	side n°
500	608	105	84	531	30	35	3	3	3
650	758	105	98	685	30	35	3	4	3
800	958	140	115	835	30	35	4	4	4
1000	1158	140	110	1030	30	35	4	6	4
1200	1408	140	121	1228	30	35	4	7	4
1400	1608	140	130	1430	30	35	4	8	4
1600	1808	140	137	1630	30	35	4	9	4
1800	2008	140	143	1833	30	35	4	10	4
2000	2208	140	148	2036	30	35	4	11	4



2 Rollers

series with rings

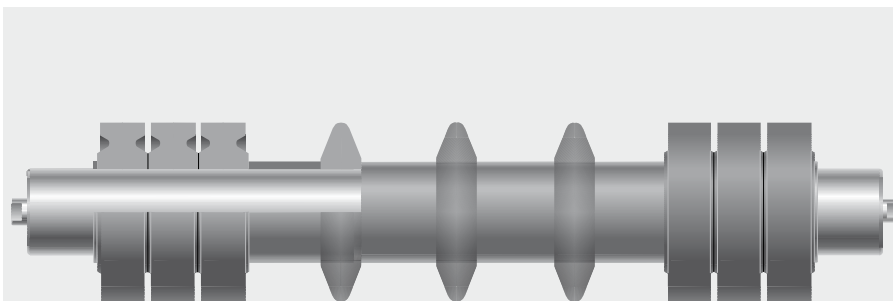

The pointed rings are held in position by PVC distance collars; the flat rings are held in position by external steel rings welded to the tube.

Øe 159 NL

Base roller:

PSV 1

D = 89;
spindle 20; d₁ = 20
bearing 6204
ch = 14

PSV 2

D = 89;
spindle 25; d₁ = 25
bearing 6205
ch = 18

PSV 4

D = 89;
spindle 30; d₁ = 30
bearing 6206
ch = 22

Example of ordering
standard design
PSV4,30F,159NL,1808

for special designs
see pages 80-81

belt	roller						rings n°
	dimensions mm			weight Kg			
width mm	B	C	A	PSV 1	PSV 2	PSV 4	total
arrangement 							
500	600	608	*	9.7			7
650	750	758	*	11.4	12.9		8
800	950	958	*	14.4	16.2	18.4	10
1000	1150	1158	*	16.9	19.0	21.5	12
1200	1400	1408	*	19.4	21.9	24.9	13
1400	1600	1608	*	21.6	24.3	27.6	14
1600	1800	1808	*	23.7	26.7	30.4	15
1800	2000	2008	*		29.2	33.2	16
2000	2200	2208	*			35.9	17

* in relation to the choice of base roller

belt	roller	rings					side n°	central	side
		length mm	a mm	b	t	E			
width mm									
500	608	100	67	546	30	50	2	3	2
650	758	100	78	696	30	50	2	4	2
800	958	150	88	843	30	50	3	4	3
1000	1158	150	84	1047	30	50	3	6	3
1200	1408	150	96	1255	30	50	3	7	3
1400	1608	150	104	1451	30	50	3	8	3
1600	1808	150	110	1653	30	50	3	9	3
1800	2008	150	121	1847	30	50	3	10	3
2000	2208	150	116	2051	30	50	3	11	3

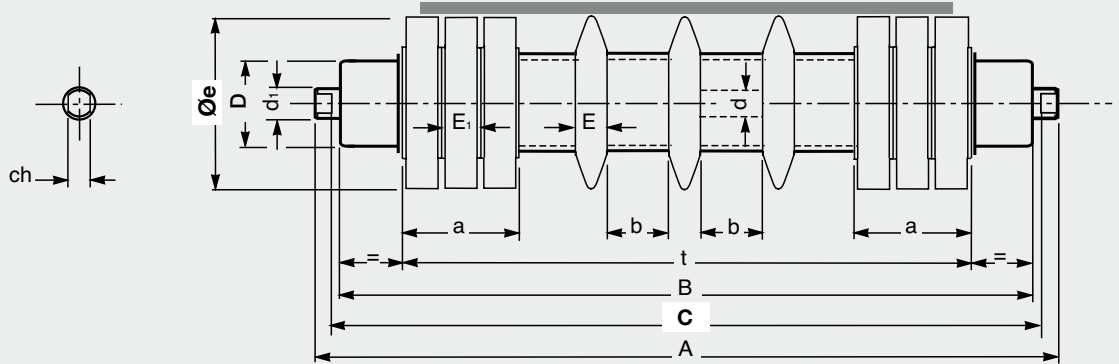

Øe 180 NL

Base roller:

PSV 1

D = 108;
spindle 20; d₁ = 20
bearing 6204
ch = 14

PSV 2

D = 108;
spindle 25; d₁ = 25
bearing 6205
ch = 18

PSV 4

D = 108;
spindle 30; d₁ = 30
bearing 6206
ch = 22

PSV/7-FHD

D = 108;
spindle 40; d₁ = 40
bearing 6308
ch = 32

belt	roller				weight				rings n°
	dimensions mm			Kg					
width mm									
arrangement	B	C	A	PSV 1	PSV 2	PSV 4	PSV/7-FHD	total	
800	950	958	*	19.9	21.8	24.1	29.6	12	
1000	1150	1158	*	23.5	25.6	28.3	34.5	14	
1200	1400	1408	*	27.0	29.5	32.5	39.7	15	
1400	1600	1608	*	29.9	32.7	36.1	44.0	16	
1600	1800	1808	*	32.8	35.9	39.6	48.3	17	
1800	2000	2008	*		39.1	43.2	52.7	18	
2000	2200	2208	*			46.7	57.0	19	
2200	2500	2508	*			52.0	63.1	20	

* in relation to the choice of base roller

belt	roller	rings						side central side		
		width mm	length mm	a	b	t	E	E ₁	n°	n°
800	958	160	76	838	40	40	4	4	4	
1000	1158	160	73	1041	40	40	4	6	4	
1200	1408	160	84	1238	40	40	4	7	4	
1400	1608	160	93	1439	40	40	4	8	4	
1600	1808	160	100	1638	40	40	4	9	4	
1800	2008	160	106	1840	40	40	4	10	4	
2000	2208	160	111	2042	40	40	4	11	4	
2200	2508	160	115	2241	40	40	4	12	4	

Example of ordering
standard design
PSV4,30F,180NL,1808

for special designs
see pages 80-81



2 Rollers

series with rings

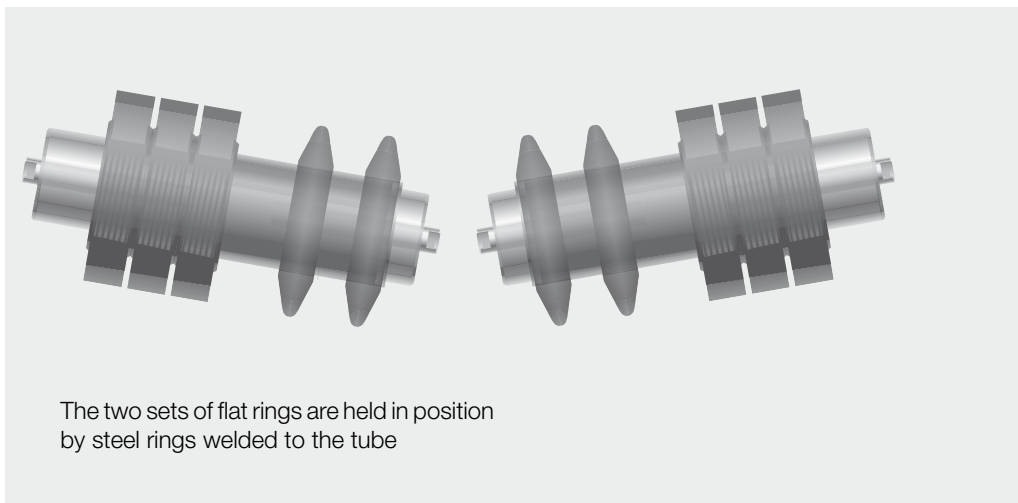

The two sets of flat rings are held in position by steel rings welded to the tube

Øe 108 NC

Base roller:

PSV 1

D = 63;
spindle 20; d₁ = 20
bearing 6204
ch = 14

belt	roller				weight Kg	rings n°
	dimensions mm					
width mm						
arrangement				PSV 1		
	B	C	A		total	
300	200	208	226	2.8	3	
400	250	258	276	3.1	3	
500	315	323	341	3.7	4	
650	380	388	406	4.2	4	
800	465	473	491	4.9	5	
1000	600	608	626	6.1	6	
1200	700	708	726	7.0	7	
1400	800	808	826	7.9	8	

roller length C mm	rings						side central	
	a mm	b	c	t	E	E ₁	n°	
208	90	60	25	175	25	45	2	1
258	90	80	25	195	25	45	2	1
323	90	70	25	255	25	45	2	2
388	90	90	30	300	25	45	2	2
473	90	95	30	405	25	45	2	3
608	135	110	40	505	25	45	3	3
708	135	105	40	595	25	45	3	4
808	180	120	40	700	25	45	4	4

Example of ordering
standard design
PSV1,20F,108NC,608

for special designs
see pages 80-81

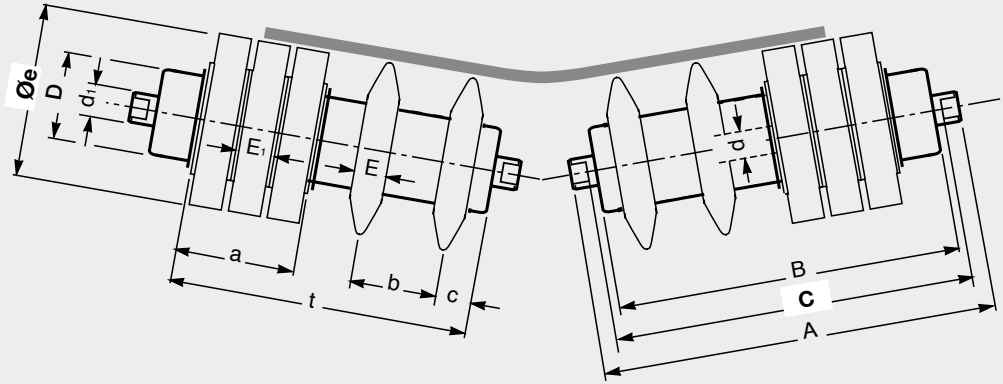
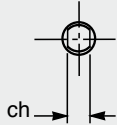

Øe 133 NC

Base roller:

PSV 1

D = 89;
spindle 20; d₁ = 20
bearing 6204
ch = 14

PSV 2

D = 89;
spindle 25; d₁ = 25
bearing 6205
ch = 18

PSV 4

D = 89;
spindle 30; d₁ = 30
bearing 6206
ch = 22

Example of ordering
standard design
PSV2,25F,133NC,808

for special designs
see pages 80-81

belt	roller			weight			rings n°
	width mm	dimensions mm		PSV 1	PSV 2	PSV 4	
arrangement		B	C	A			total
							
500	315	323	*	4.8			5
650	380	388	*	5.4	6.5		5
800	465	473	*	6.5	7.7	9.1	6
1000	600	608	*	7.9	9.3	10.9	7
1200	700	708	*	9.1	10.6	12.4	8
1400	800	808	*	10.0	11.7	13.6	8
1600	900	908	*	11.2	13.0	15.1	9
1800	1000	1008	*		14.0	16.3	10
2000	1100	1108	*			17.8	11

* in relation to the choice of base roller

roller length C mm	rings						side n°	central n°
	a mm	b	c	t	E	E ₁		
323	105	70	30	275	30	35	3	2
388	105	85	30	305	30	35	3	2
473	105	90	30	405	30	35	3	3
608	140	105	40	495	30	35	4	3
708	140	105	40	600	30	35	4	4
808	140	130	40	700	30	35	4	4
908	140	125	40	805	30	35	4	5
1008	140	120	50	910	30	35	4	6
1108	140	120	50	1030	30	35	4	7



2 Rollers

series with rings

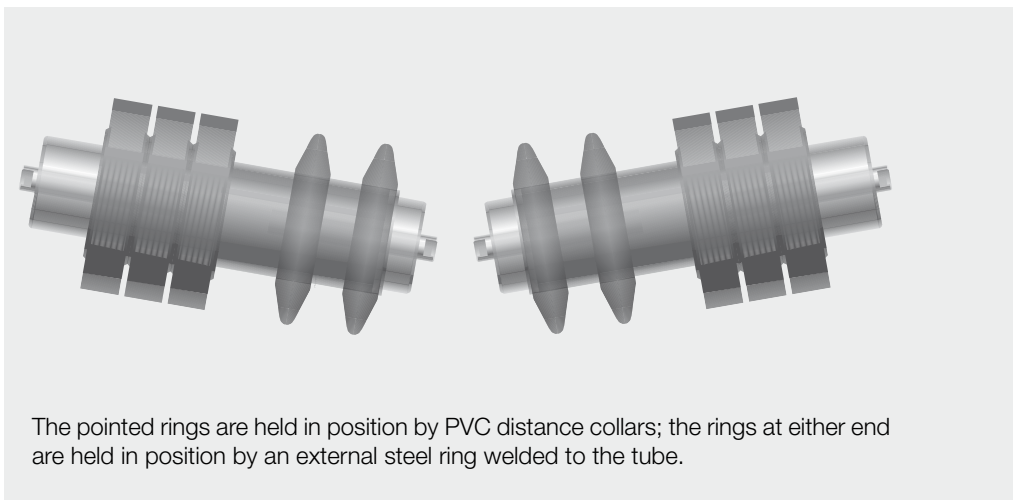

The pointed rings are held in position by PVC distance collars; the rings at either end are held in position by an external steel ring welded to the tube.

Øe 159 NC

Base roller:

PSV 1

D = 89;
spindle 20; d₁ = 20
bearing 6204
ch = 14

PSV 2

D = 89;
spindle 25; d₁ = 25
bearing 6205
ch = 18

PSV 4

D = 89;
spindle 30; d₁ = 30
bearing 6206
ch = 22

Example of ordering
standard design
PSV2,25F,159NC,908

for special designs
see pages 80-81

belt	roller						rings n°
	dimensions mm			weight Kg			
width mm							
arrangement	B	C	A	PSV 1	PSV 2	PSV 4	total
500	315	323	*	5.5			4
650	380	388	*	6.1	6.8		4
800	465	473	*	7.2	8.1	9.4	5
1000	600	608	*	9.0	10.1	11.6	6
1200	700	708	*	10.3	11.4	13.2	7
1400	800	808	*	11.2	12.5	14.4	7
1600	900	908	*	12.4	13.9	16.0	8
1800	1000	1008	*		15.3	17.5	9
2000	1100	1108	*			18.9	10

* in relation to the choice of base roller

roller length C mm	rings						side central n°	
	a	b	c	t	E	E ₁		
323	100	40	30	253	30	50	2	2
388	100	65	30	303	30	50	2	2
473	100	65	30	396	30	50	2	3
608	150	85	40	516	30	50	3	3
708	150	85	40	629	30	50	3	4
808	150	110	40	729	30	50	3	4
908	150	100	40	817	30	50	3	5
1008	150	95	50	925	30	50	3	6
1108	150	95	50	1048	30	50	3	7

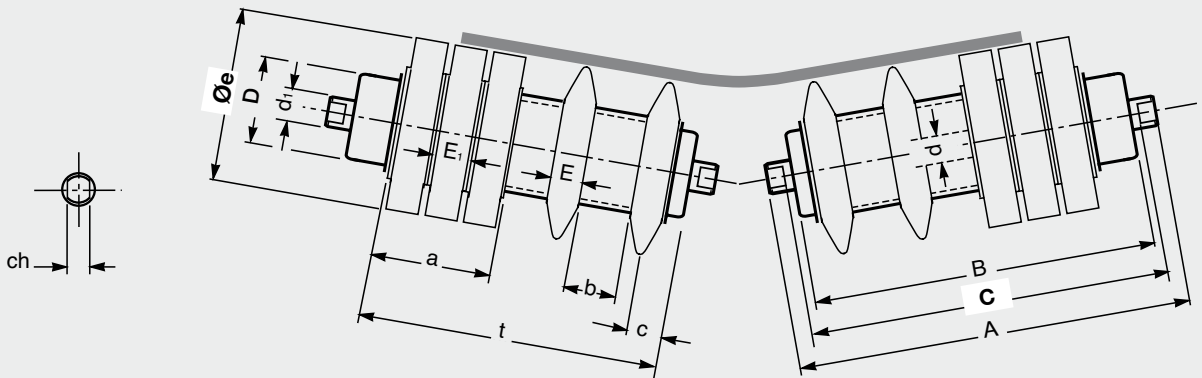

Øe 180 NC

Base roller:

PSV 1

D = 108;
spindle 20; d₁ = 20
bearing 6204
ch = 14

PSV/7-FHD

D = 108;
spindle 40; d₁ = 40
bearing 6308
ch = 32

PSV 2

D = 108;
spindle 25; d₁ = 25
bearing 6205
ch = 18

PSV 4

D = 108;
spindle 30; d₁ = 30
bearing 6206
ch = 22

belt	roller				weight				rings n°
	width mm	dimensions mm			Kg				
arrangement 	B	C	A	PSV 1	PSV 2	PSV 4	PSV/7-FHD	total	
				800	465	473	*		10.2
1000	600	608	*	12.5	13.5	15.1	20.0	7	
1200	700	708	*	14.2	15.4	17.2	22.4	8	
1400	800	808	*	15.4	16.7	18.6	24.3	8	
1600	900	908	*	17.2	18.6	20.7	26.7	9	
1800	1000	1008	*		20.5	22.8	29.1	10	
2000	1100	1108	*			24.9	31.6	11	
2200	1250	1258	*			27.7	34.9	12	

* in relation to the choice of base roller

roller length C mm	rings						side central	
	a mm	b	c	t	E	E ₁	n°	n°
473	120	60	45	435	40	40	3	3
608	160	70	45	515	40	40	4	3
708	160	75	45	645	40	40	4	4
808	160	100	45	745	40	40	4	4
908	160	90	45	835	40	40	4	5
1008	160	85	55	945	40	40	4	6
1108	160	85	55	1070	40	40	4	7
1258	160	85	55	1195	40	40	4	8

Example of ordering
standard design
PSV2,25F,180NC,908

for special designs
see pages 80-81