

2.5.5 - Rollers series RTL

Where used

The roller series RTL has been designed to be used in the movement of small or light loads.

The roller consists of a special steel tube swaged over the bearing housings which are made from technopolymers which have high elastic properties, and resistance to mechanical forces and to corrosion.

The standard design utilises rigid radial precision ball bearings, lubricated for life, a spindle of $\varnothing 15$ mm with locking bush with spanner flats $ch = 17$ mm.

A double radial labyrinth protects the bearing to allow use in medium severe environmental conditions.

In the following tables the diameters in production are indicated with their loads at varying recommended speeds.

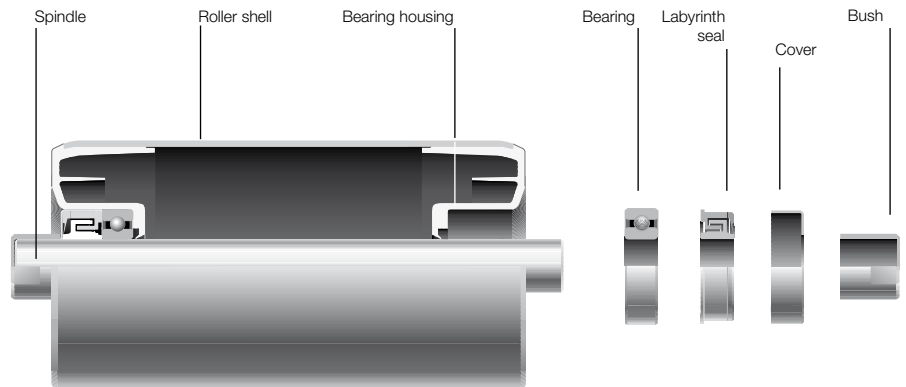

The table indicates the roller diameters in production. On request they may be supplied with different dimensions to the standard and with $ch = 14$ mm.

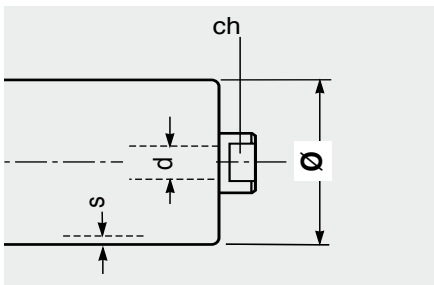

Programme of production series RTL

roller type	\varnothing mm	basic design	s	spindle d	ch	bearing	note
RTL 1	60	N	2	15	17	6202	with tube and spindle in steel S235JR (EN 10027-1) ex Fe360 (EN 10025) St37 (DIN 17100)
	76	N	2				
	89	N	2				



2 Rollers

series RTL 1

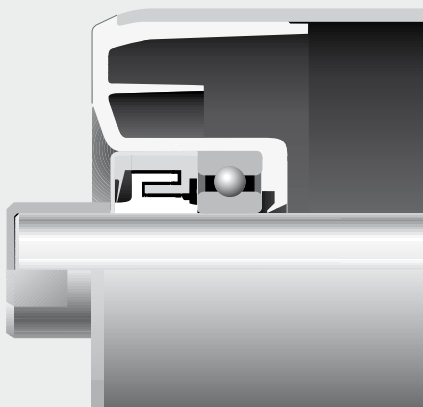

Section through seal

Ø 60 N

Bearing 6202
(15 x 35 x 11)

d = 15
d₁ = 20
ch = 17 *
s = 2
e = 4
g = 9

*ch = 14 upon
request

belt width mm	roller dimensions mm			weight Kg		load capacity daN					
	B	C	A	rotating parts	total	belt speed m/s					
arrangements 						0.4	0.6	0.8	1	1.25	1.5
400	160	168	186	0.6	0.9	113	99	90	83	77	73
300 500	200	208	226	0.8	1.1	113	99	90	83	77	73
400 650	250	258	276	0.9	1.3	113	99	90	83	77	73
500 800	315	323	341	1.1	1.6	113	99	90	83	77	73
300 650 1000	380	388	406	1.3	1.8	113	99	90	83	77	73
800	465	473	491	1.5	2.2	113	99	90	83	77	73
400	500	508	526	1.6	2.3	108	99	90	83	77	73
500 1000	600	608	626	1.9	2.8	89	89	89	83	77	73
650	750	758	776	2.3	3.4	71	71	71	71	71	71
800	950	958	976	2.9	4.3	57	57	57	51	51	51
1000	1150	1158	1176	3.5	5.1	48	48	48	48	48	48

The indicated load capacity relates to a project working of 10,000 hours.

Example of ordering
standard design
RTL1,15B,60N,258

for special designs
see pages 80-81

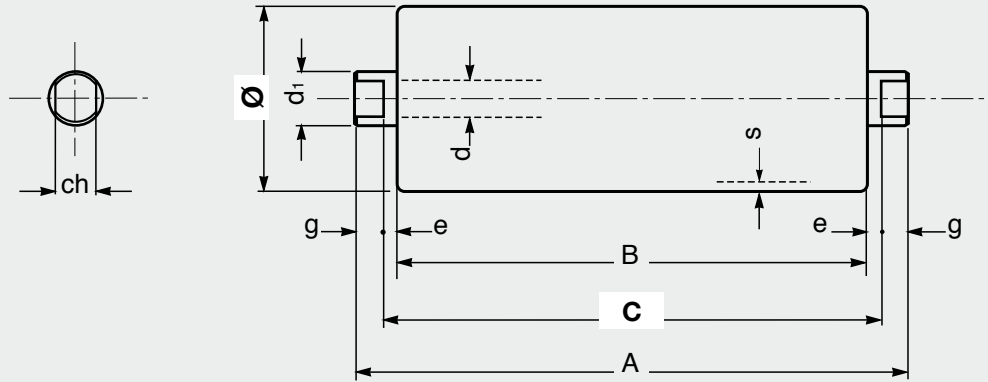

Ø 76 N

Bearing 6202
(15 x 35 x 11)

d = 15
d₁ = 20
ch = 17 *
s = 2
e = 4
g = 9

*ch = 14 upon
request

belt	roller			weight		load capacity					
	width mm	dimensions mm			Kg		daN				
arrangements 	B	C	A	rotating		belt speed m/s					
				parts	total	0.5	0.75	1	1.25	1.5	1.75
400	160	168	186	0.8	1.1	114	99	90	84	79	75
300 500	200	208	226	1.0	1.3	114	99	90	84	79	75
400 650	250	258	276	1.1	1.5	114	99	90	84	79	75
500 800	315	323	341	1.4	1.8	114	99	90	84	79	75
300 650 1000	380	388	406	1.6	2.2	114	99	90	84	79	75
800	465	473	491	1.9	2.6	113	99	90	84	79	75
400	500	508	526	2.1	2.8	105	99	90	84	79	75
500 1000	600	608	626	2.4	3.3	86	86	86	86	86	86
650	750	758	776	3.0	4.0	69	69	69	69	69	69
800	950	958	976	3.7	5.0	54	54	54	54	54	54
1000	1150	1158	1176	4.4	6.1	45	45	45	45	45	45

The indicated load capacity relates to a project working of 10,000 hours.

Example of ordering
standard design
RTL1,15B,76N,323

for special designs
see pages 80-81



2 Rollers

series RTL 1

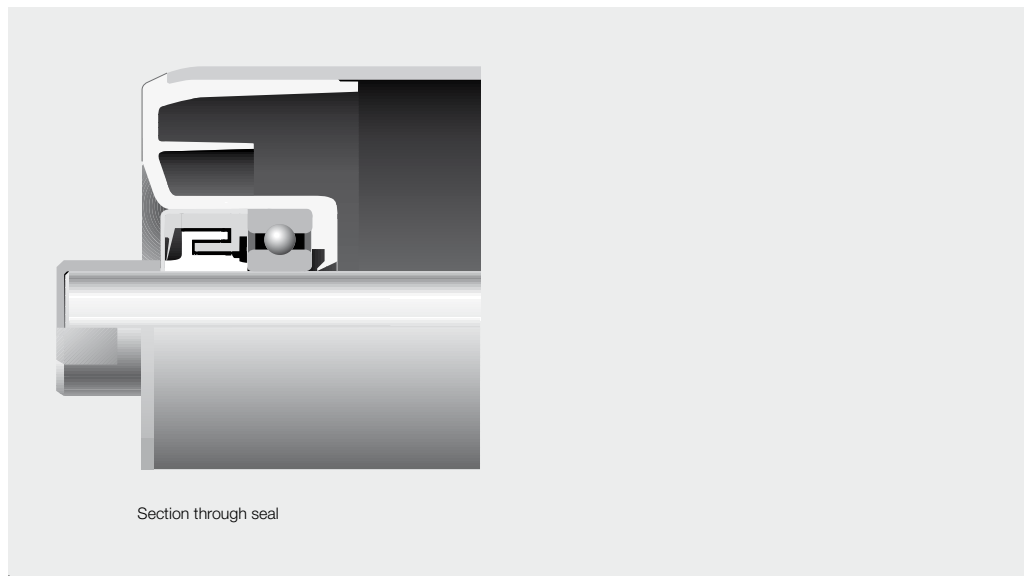

Section through seal

Ø 89 N

Bearing 6202
(15 x 35 x 11)

d = 15
d₁ = 20
ch = 17 *
s = 2
e = 4
g = 9

*ch = 14 upon
request

belt width mm	roller dimensions mm						weight Kg		load capacity daN					
	arrangements 			B	C	A	rotating parts	total	belt speed m/s					
									0.75	1	1.25	1.5	1.75	2
400	160	168	186	1.1	1.4	105	95	88	83	79	75			
300 500	200	208	226	1.3	1.6	105	95	88	83	79	75			
400 650	250	258	276	1.5	1.9	105	95	88	83	79	75			
500 800	315	323	341	1.8	2.3	105	95	88	83	79	75			
300 650 1000	380	388	406	2.1	2.6	105	95	88	83	79	75			
800	465	473	491	2.4	3.1	105	95	88	83	79	75			
400	500	508	526	2.6	3.3	104	95	88	83	79	75			
500 1000	600	608	626	3.0	3.9	85	85	85	83	79	75			
650	750	758	776	3.7	4.7	68	68	68	68	68	68			
800	950	958	976	4.5	5.9	53	53	53	53	53	53			
1000	1150	1158	1176	5.4	7.0	44	44	44	44	44	44			

The indicated load capacity relates to a project working of 10,000 hours.

Example of ordering
standard design
RTL1,15B,89N,758

for special designs
see pages 80-81

